

# Lecture Notes

ON

STRUCTURAL DESIGN-I

Prepared By: -Er.Deepak Mohapatra



DEPARTMENT OF CIVIL ENGINEERING

Ganesh Institute of Engineering and Technology, BBSR

# DESIGN OF CONCRETE STRUCTURES

## **Introduction**

Reinforced concrete, as a composite material, has occupied a special place in the modern construction of different types of structures due to its several advantages. Due to its flexibility in form and superiority in performance, it has replaced, to a large extent, the earlier materials like stone, timber and steel. Further, architect's scope and imaginations have widened to a great extent due to its mouldability and monolithicity. Thus, it has helped the architects and engineers to build several attractive shell forms and other curved structures. However, its role in several straight line structural forms like multistoried frames, bridges, foundations etc. is enormous.

## **Concrete**

Concrete is a product obtained artificially by hardening of the mixture of cement, sand, gravel and water in predetermined proportions.

Depending on the quality and proportions of the ingredients used in the mix the properties of concrete vary almost as widely as different kinds of stones.

Concrete has enough strength in compression, but has little strength in tension. Due to this, concrete is weak in bending, shear and torsion. Hence the use of plain concrete is limited to applications where great compressive strength and weight are the principal requirements and where tensile stresses are either totally absent or are extremely low.

## **Properties of Concrete**

The important properties of concrete, which govern the design of concrete mix are as follows

### (i) Weight

The unit weights of plain concrete and reinforced concrete made with sand, gravel of crushed natural stone aggregate may be taken as  $24 \text{ kN/m}^3$  and  $25 \text{ kN/m}^3$  respectively.

### (ii) Compressive Strength

With given properties of aggregate the compressive strength of concrete depends primarily on age, cement content and the water-cement ratio as given in Table 2 of IS 456:2000. Characteristic strength are based on the strength at 28 days. The strength at 7 days is about two-thirds of that at 28 days with ordinary portland cement and generally good indicator of strength likely to be obtained.

### (iii) Increase in strength with age

There is normally gain of strength beyond 28 days. The quantum of increase depends upon the grade and type of cement curing and environmental conditions etc.

(iv) **Tensile strength of concrete**

The flexure and split tensile strengths of various concrete are given in IS 516:1959 and IS 5816:1970 respectively when the designer wishes to use an estimate of the tensile strength from compressive strength, the following formula can be used

$$\text{Flexural strength, } f_{cr} = 0.7 \sqrt{f_{ck}} \text{ N/mm}^2$$

(v) **Elastic Deformation**

The modulus of elasticity is primarily influenced by the elastic properties of the aggregate and to lesser extent on the conditions of curing and age of the concrete, the mix proportions and the type of cement. The modulus of elasticity is normally related to the compressive characteristic strength of concrete

$$E_c = 5000 \sqrt{f_{ck}} \text{ N/mm}^2$$

Where  $E_c$  = the short-term static modulus of elasticity in

$\text{N/mm}^2$   $f_{ck}$  = characteristic cube strength of concrete in  $\text{N/mm}^2$

(vi) **Shrinkage of concrete**

Shrinkage is the time dependent deformation, generally compressive in nature. The constituents of concrete, size of the member and environmental conditions are the factors on which the total shrinkage of concrete depends. However, the total shrinkage of concrete is most influenced by the total amount of water present in the concrete at the time of mixing for a given humidity and temperature. The cement content, however, influences the total shrinkage of concrete to a lesser extent. The approximate value of the total shrinkage strain for design is taken as 0.0003 in the absence of test data (cl. 6.2.4.1).

(vii) **Creep of concrete**

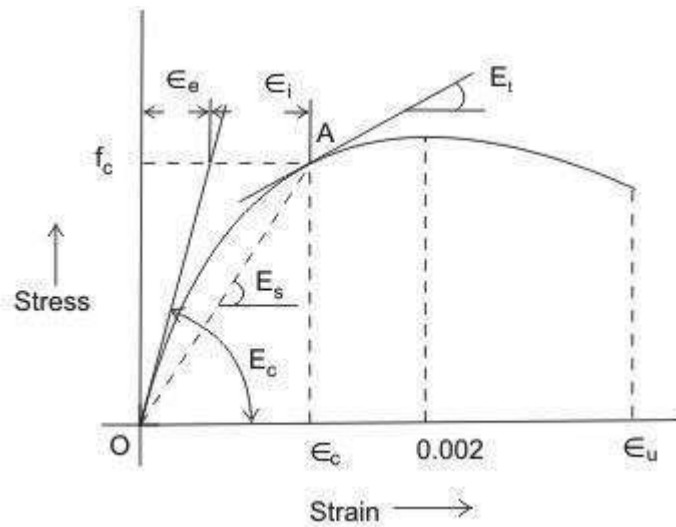

Figure 1.1: Stress-strain curve of concrete

Creep is another time dependent deformation of concrete by which it continues to deform, usually under compressive stress. The creep strains recover partly when the stresses are released. Figure 1.2.2 shows the creep recovery in two parts. The elastic recovery is immediate and the creep recovery is slow in nature.

Thus, the long term deflection will be added to the short term deflection to get the total deflection of the structure. Accordingly, the long term modulus  $E_{ce}$  or the effective modulus of concrete will be needed to include the effect of creep due to permanent loads. The relationship between  $E_{ce}$  and  $E_c$  is obtained as follows:

$$\epsilon_c = f_c / E_c$$

Where,  $\epsilon_c$  = short term strain at the age of loading at a stress value of  $f_c$

$$\theta = \text{creep coefficient} = \frac{\epsilon_{cr}}{\epsilon_c}$$

$\epsilon_{cr}$  = ultimate creep strain

The values of  $\theta$  on 7, 28 and 365<sup>th</sup> day of loading are 2.2, 1.6 and 1.1 respectively.

$$\text{The total strain} = \epsilon_c + \epsilon_{cr} = \frac{f_c}{E_{ce}}$$

Where,  $E_{ce}$

= effective modulus of concrete. From the above

Equation, we have

$$E_{ce} = \frac{f_c}{\epsilon_c + \epsilon_{cr}} = \frac{\epsilon_c}{\epsilon_c + \epsilon_{cr}} \frac{E_c}{1 + \theta}$$

The effective modulus of  $E_{ce}$  of concrete is used only in the calculation of creep deflection.

It is seen that the value of creep coefficient  $\theta$  is reducing with the age of concrete at loading. It

may also be noted that the ultimate creep  $\epsilon_{cr}$  does not include short term strain  $\epsilon_c$ . The strain creep of concrete is influenced by

- Properties of concrete
- Water/cement ratio
- Humidity and temperature of curing
- Humidity during the period of use
- Age of concrete at first loading
- Magnitude of stress and its duration
- Surface-volume ratio of the member

#### **(f) Thermal expansion of concrete**

The knowledge of thermal expansion of concrete is very important as it is prepared and remains in service at a wide range of temperature in different countries having very hot or cold climates. Moreover, concrete will be having its effect of high temperature during fire. The coefficient of thermal expansion depends on the nature of cement, aggregate, cement content, relative humidity and size of the section. IS 456 stipulates (cl. 6.2.6) the values of coefficient of thermal expansion for concrete/  $C_f$  for different types of aggregate.

#### **Workability and Durability of Concrete**

Workability and durability of concrete are important properties to be considered. The relevant issues are discussed in the following:

The workability of a concrete mix gives a measure of the ease with which fresh concrete can be placed and compacted. The concrete should flow readily into the form and go around and cover the reinforcement, the mix should retain its consistency and the aggregates should not segregate. A mix with high workability is needed where sections are thin and/or reinforcement is complicated and congested. The main factor affecting workability is the water content of the mix. Admixtures will increase workability but may reduce strength. The

size of aggregate, its grading and shape, the ratio of coarse to fine aggregate and the aggregate-to-cement ratio also affect workability to some degree.

### **Measurement of workability**

#### *(a) Slump test*

The fresh concrete is tamped into a standard cone which is lifted off after filling and the slump is measured. The slump is 25–50 mm for low workability, 50–100 mm for medium workability and 100–175 mm for high workability. Normal reinforced concrete requires fresh concrete of medium workability. The slump test is the usual workability test specified.

#### *(b) Compacting factor test*

The degree of compaction achieved by a standard amount of work is measured. The apparatus consists of two conical hoppers placed over one another and over a cylinder. The upper hopper is filled with fresh concrete which is then dropped into the second hopper and into the cylinder which is struck off flush. The compacting factor is the ratio of the weight of concrete in the cylinder to the weight of an equal volume of fully compacted concrete. The compacting factor for concrete of medium workability is about 0.9.

### **Durability of concrete**

A durable concrete performs satisfactorily in the working environment during its anticipated exposure conditions during service. The durable concrete should have low permeability with adequate cement content, sufficient low free water/cement ratio and ensured complete compaction of concrete by adequate curing. For more information, please refer to cl. 8 of IS 456.

### **Design mix and nominal mix concrete**

In design mix, the proportions of cement, aggregates (sand and gravel), water and mineral admixtures, if any, are actually designed, while in nominal mix, the proportions are nominally adopted. The design mix concrete is preferred to the nominal mix as the former results in the grade of concrete having the specified workability and characteristic strength (vide cl. 9 of IS 456).

### **Batching**

Mass and volume are the two types of batching for measuring cement, sand, coarse aggregates, admixtures and water. Coarse aggregates may be gravel, grade stone chips or other man-made aggregates. The quantities of cement, sand, coarse aggregates and solid admixtures shall be measured by mass. Liquid admixtures and water are measured either by volume or by mass (cl. 10 of IS 456).

### **Properties of reinforcing steel**

Steel reinforcement used in reinforced concrete may be of the following types

(a) 1. Mild steel bars conforming to IS 432 (part-I)

2. Hot rolled mild steel conforming to IS 1139

(b) 1. Medium tensile steel conforming to IS 432 (part-I)

2. Hot rolled medium tensile steel.

(c) 1. Hot rolled High Yield Strength Deformed (HYSD) steel conforming to IS 1139.

2. Cold-worked steel HYSD bars conforming to IS 1786.

(d) 1. Hard drawn steel wire fabric conforming to IS 1566.

2. Rolled steel made from structural steel conforming to IS 226.

1. The most important characteristic of a reinforcing bar is its stress strain curve and the important property yield stress or 0.2% proof stress, as the case may be.

2. The modulus of elasticity  $E$  for these steels is  $2 \times 10^5 \text{ N/mm}^2$ .

3. Mild steel bars have yield strength of  $250 \text{ N/mm}^2$  and hence it is known as Fe 250.

4. HYSD bars may be hot rolled high yield strength bars or cold rolled steel high strength deformed bars. The latter are also known as cold twisted deformed bars or Tor steel and are available in different grades

i) Fe 415 ii) 500 iii) Fe 550 having 0.2% proof stress as  $415 \text{ N/mm}^2$ ,  $500 \text{ N/mm}^2$  and  $550 \text{ N/mm}^2$

5. The reinforcing bars should have sufficient % of elongation.

6. Its coefficient of thermal expansion should be more or less equal to the cement concrete.

**Stress-strain curves for reinforcement**

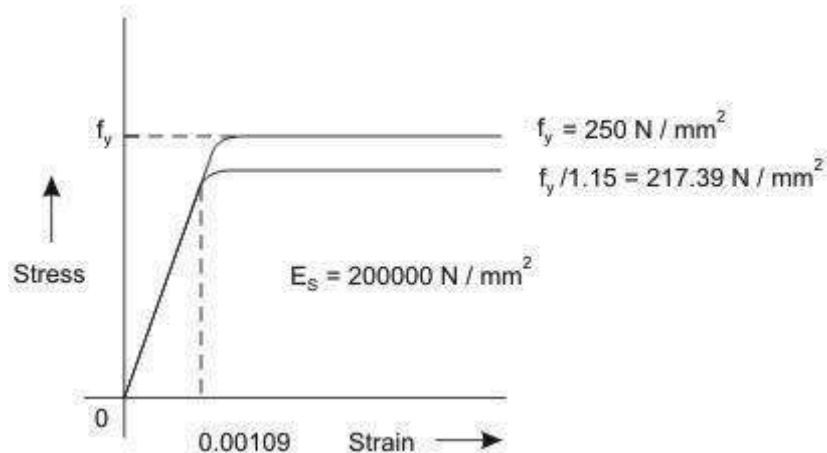

Figure 1.2: Stress-strain curve for Mild steel (idealised) (Fe250) with definite yield point

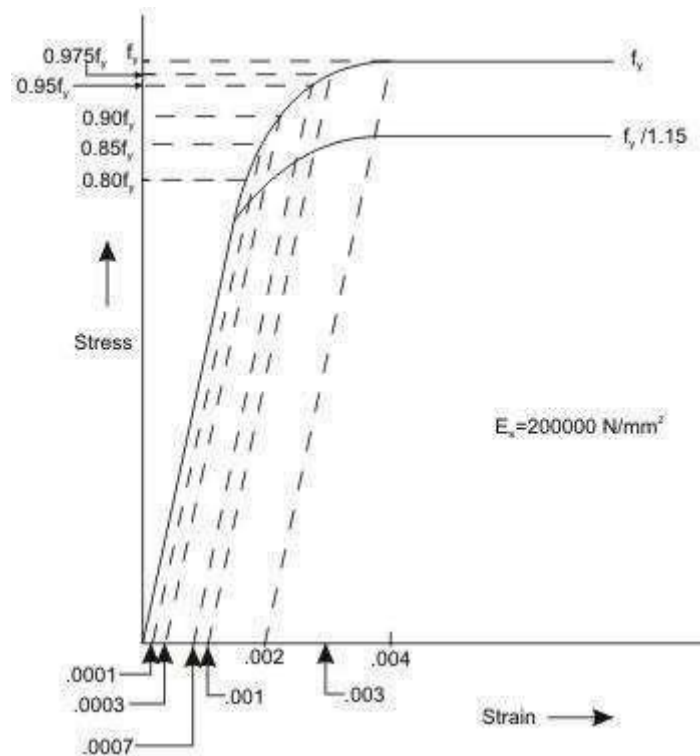

Figure 1.3: Stress-strain curve for coldworked deformbar

Figures 1.2 and 1.3 show the representative stress-strain curves for steel having definite yield point and no definite yield point, respectively. The characteristic yield strength of steel is assumed as the minimum yield stress or 0.2 percent of proof stress for steel having no definite yield point. The modulus of elasticity of steel is taken to be  $200000 \text{ N/mm}^2$ .

For mild steel, the stress is proportional to the strain up to the yield point. Thereafter, post yield strain increases faster while the stress is assumed to remain at constant value of  $f_y$ .

For cold-worked bars (Fig. 1.3), the stress is proportional to the strain up to a stress of  $0.8f_y$ .

Thereafter, the inelastic curve is defined as given below:

Stress	Inelastic strain
$0.80f_y$	Nil
$0.85f_y$	0.0001
$0.90f_y$	0.0003
$0.95f_y$	0.0007
$0.975f_y$	0.0010
$1.00f_y$	0.0020

Linear interpolation is to be done for intermediate values. The two grades of cold-worked bars used as steel reinforcement are Fe 415 and Fe 500 with the values of  $f_y$  as 415 N/mm<sup>2</sup> and 500 N/mm<sup>2</sup>, respectively.

### Method of RCC design

Reinforced concrete structures should be designed to satisfy the following criteria-

- i) Adequate safety, in items stiffness and durability
- iii) Reasonable economy.

The following design methods are used for the design of RCC structures.

- a) The working stress method (WSM)
- b) The ultimate load method (ULM)
- c) The limit state method (LSM)

### Working Stress Method (WSM)

This method is based on linear elastic theory or the classical elastic theory. This method ensures adequate safety by suitably restricting the stress in the materials (i.e. concrete and steel) induced by the expected working loads on the structures. The assumption of linear elastic behaviour is considered justifiable since the specified permissible stresses are kept well below the ultimate strength of the material. The ratio of yield stress of the steel reinforcement or the cube strength of the concrete to the corresponding permissible or working stress is usually called factor of safety.

The WSM uses a factor of safety of about 3 with respect to the cube strength of concrete and a factor of safety of about 1.8 with respect to the yield strength of steel.

### Ultimate load method (ULM)

The method is based on the ultimate strength of reinforced concrete at ultimate load is obtained by enhancing the service load by some factor called as load factor for giving a desired margin of safety. Hence the method is also referred to as the load factor method or the ultimate strength method.

In the ULM, stress condition at the state of impending collapse of the structure is analysed, thus using, the non-linear stress – strain curves of concrete and steel. The safety measure in the design is obtained by the use of proper load factor. The satisfactory strength performance at ultimate loads does not guarantee satisfactory strength performance at ultimate loads does not guarantee satisfactory serviceability performance at normal service loads.

### **Limit state method (LSM)**

Limit states are the acceptable limits for the safety and serviceability requirements of the structure before failure occurs. The design of structures by this method will thus ensure that they will not reach limit states and will not become unfit for the use for which they are intended. It is worth mentioning that structures will not just fail or collapse by violating (exceeding) the limit states. Failure, therefore, implies that clearly defined limit states of structural usefulness has been exceeded.

Limit states are two types

- i) Limit state of collapse
- ii) Limit state of serviceability.

### **Limit states of collapse**

The limit state of collapse of the structure or part of the structure could be assessed from rupture of one or more critical sections and from buckling due to elastic bending, shear, torsion and axial loads at every section shall not be less than the appropriate value at that section produced by the probable most unfavourable combination of loads on the structure using the appropriate factor of safety.

### **Limit state of serviceability**

Limit state of serviceability deals with deflection and cracking of structures under service loads, durability under working environment during their anticipated exposure conditions during service, stability of structures as a whole, fire resistance etc.

### **Characteristic and design values and partial safety factor**

## 1.Characteristic strength of materials.

The term ‘characteristic strength’ means that value of the strength of material below which not more than minimum acceptable percentage of test results are expected to fall. IS456:2000 have accepted the minimum acceptable percentage as 5% for reinforced concrete structures. This means that there is 5% probability or chance of the actual strength being less than the characteristic strength.

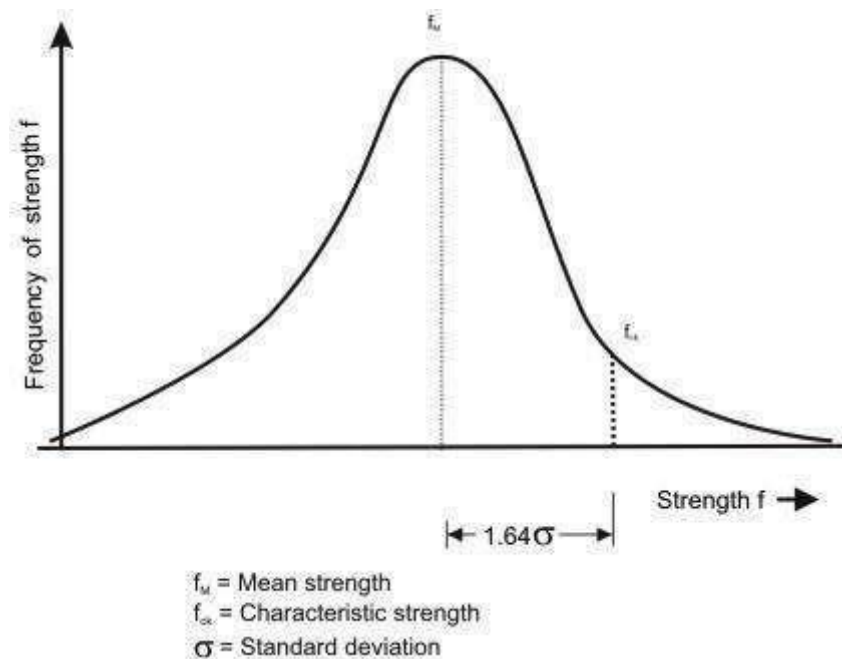

Figure 1.4: Frequency distribution curve for strength

Figure shows frequency distribution curve of strength material (concrete or steel). The value of  $K$  corresponding to 5% area of the curve is 1.65.

The design strength should be lower than the mean strength

( $f_m$ ) Characteristic strength = Mean strength  $-K \times$  standard

deviation or  $f_k = f_m - K S_d$

Where,  $f_k$  = characteristic strength of the

material  $f_m$  = mean strength

$K$  = constant = 1.65

$S_d$  = standard deviation for a set of test results.

The value of standard deviation ( $S_d$ ) is given by

$$S_d = \sqrt{\frac{\sum \delta^2}{n-1}}$$

Where,  $\delta$  = deviation of the individual test strength from the average or mean strength of n samples.

n = number of test results.

IS 456:2000 has recommended minimum value of n = 30.

### Characteristic strength of concrete

Characteristic strength of concrete is denoted by  $f_{ck}$  (N/mm<sup>2</sup>) and its value is different for different grades of concrete e.g. M 15, M25 etc. In the symbol 'M' used for designation of concrete mix, refer to the mix and the number refer to the specified characteristic compressive strength of 150 mm size cube at 28 days expressed in N/mm<sup>2</sup>

### Characteristic strength of steel

Until the relevant Indian Standard specification for reinforcing steel are modified to include the concept of characteristic strength, the characteristic values shall be assumed as the minimum yield stress or 0.2% proof stress specified in the relevant Indian Standard specification. The characteristic strength of steel designated by symbol  $f_y$  (N/mm<sup>2</sup>)

### Characteristic loads

The term 'Characteristic load' means that values of load which has a 95% probability of not being exceeded during that life of the structure.

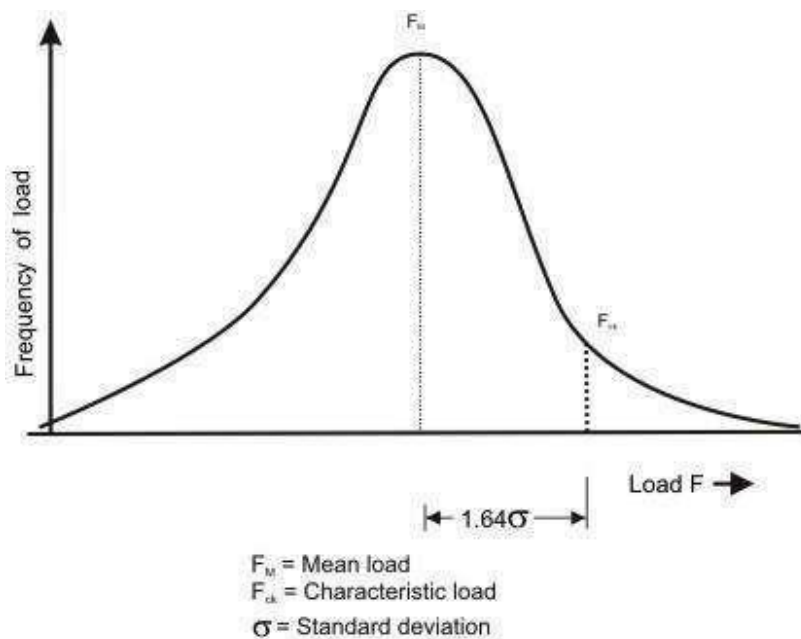

Figure 1.5: Frequency distribution curve for load

The design load should be more than average load obtained from statistic, we have  $F_k = F_m + K S_d$

Where,  $F_k$  = characteristic

load;  $F_m$  = mean load  $K$  =

constant = 2.65;

$S_d$  = standard deviation for the load.

Since data are not available to express loads in statistical terms, for the purpose of this standard, dead loads given in IS 875 (Part-1), imposed loads given in IS 875 (Part-2), wind loads. Given in IS 875 (Part-3), snow load as given in IS 875 (Part-4) and seismic forces given in IS 1893 shall be assumed as the characteristic loads.

### Design strength of materials

The design strength of materials ( $f_d$ ) is given by

$$f_d = \frac{f_k}{m}$$

Where,  $f_k$  = characteristic strength of material.

$\gamma_m$  = partial safety factor appropriate to the material and the limit state being considered

### Design loads

The design load ( $F_d$ ) is given by  $F_d =$

$$F_k \cdot \gamma_f$$

$\gamma_f$  = partial safety factor appropriate to the nature of loading and the limit state being considered.

The design load obtained by multiplying the characteristic load by the partial safety factor for load is also known as factored load.

### Partial safety factor ( $\gamma_m$ ) for materials

When assessing the strength of a structure or structural member for the limit state of collapse, the values of partial safety factor,  $\gamma_m$  should be taken as 1.15 for steel.

Thus, in the limit state method, the design stress for steel reinforcement is given by  $f_y / \gamma_{ms} = f_y / 1.15 = 0.87 f_y$ .

According to IS 456:2000 for design purpose the compressive strength of concrete in the structure shall be assumed to be 0.67 times the characteristic strength of concrete in cube and partial safety factor  $\gamma_{mc} = 1.5$  shall be applied in addition to this. Thus, the design stress in concrete is given by

$$0.67f_{ck}/\gamma_{mc} = 0.67f_{ck}/1.5 = 0.446f_{ck}$$

### Partial safety factor for loads

The partial safety factors for loads, as per IS 456:2000 are given in table below

Load combination	Limit State of collapse			Limit State of Serviceability		
	DL	LL	WL/EL	DL	LL	WL/EL
DL+IL	1.5	1.5	-	1.0	1.0	-
DL+WL	1.5 or 0.9*	-	1.5	1.0	-	1.0
DL+IL+WL	1.2	1.2	1.2	1.0	0.8	0.8

(\* This value is to be considered when stability against overturning or stress reversal is critical)

### Limit state of collapse in flexure

The behaviour of reinforced concrete beam sections at ultimate loads has been explained in detail in previous section. The basic assumptions involved in the analysis at the ultimate limit state of flexure (Cl. 38.1 of the Code) are listed here.

- Plane sections normal to the beam axis remain plane after bending, i.e., in an initially straight beam, strain varies linearly over the depth of the section.
- The maximum compressive strain in concrete (at the outermost fibre)  $0.0035 \epsilon_{cu}$  shall be taken as 35 in bending.
- The relationship between the compressive stress distribution in concrete and the strain in concrete may be assumed to be rectangle, trapezoid, parabola or any other shape which results in prediction of strength in substantial agreement with the results of test. An acceptable stress-strain curve is given below in figure 1.6. For design purposes, the compressive strength of concrete in the structure shall be assumed to be 0.67 times the characteristic strength. The partial safety factor,  $= 1.5$  shall be applied in addition to this.

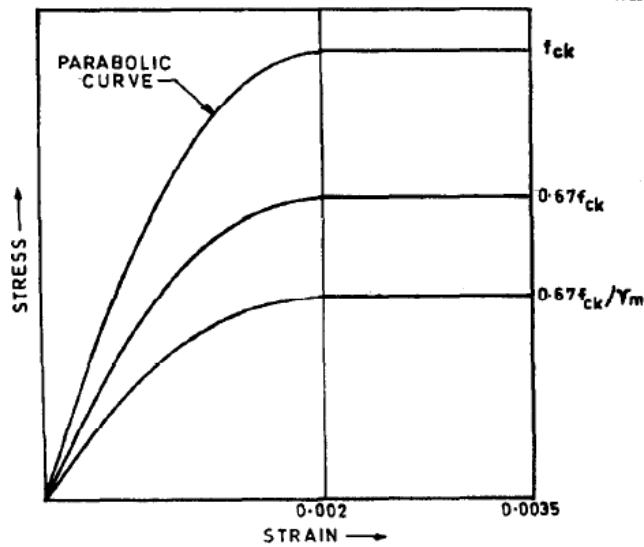

Figure 1.6 Stress-strain curve for concrete

- d) The tensile strength of the concrete is ignored.
- e) The stresses in the reinforcement are derived from representative stress-strain curve for the type of steel used. Typical curves are given in figure 1.3. For design purposes the partial safety factor  $\gamma_m$  equal to 1.15 shall be applied.
- f) The maximum strain in the tension reinforcement in the section at failure shall not be less than:

$$\frac{f_y}{1.15E_s} + 0.002$$

### Limiting Depth of Neutral Axis

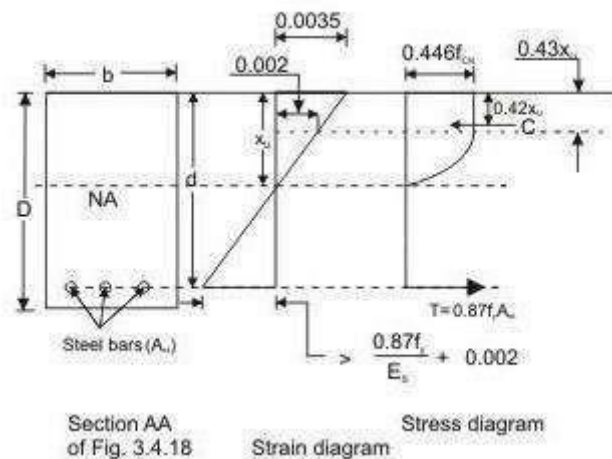

Figure: 1.7 Rectangular beam under flexure  $x_u < x_{u,max}$

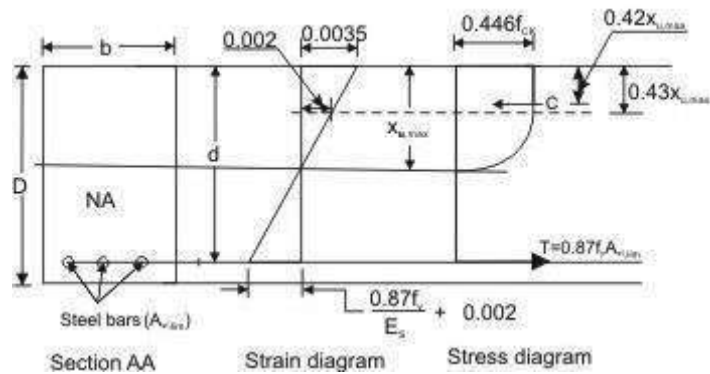

Figure 1.8 Rectangular beam under flexure  $x_u = x_{u,max}$

Based on the assumption given above, an expression for the depth of the neutral axis at the ultimate limit state,  $x_u$ , can be easily obtained from the strain diagram in Fig. 1.8. Considering similar triangles,

$$\frac{x_u}{d} = \frac{0.0035}{0.0035 + \frac{0.87f_y}{E_s} + 0.002} \quad (1)$$

According to IS 456:2000 clno 38.1(f), when the maximum strain in tension reinforcement is equal to  $0.87f_y/E_s + 0.002$ , then the value of neutral axis will be

$$\text{Therefore, } \frac{x_{u,max}}{d} = \frac{0.0035}{0.0035 + \frac{0.87f_y}{E_s} + 0.002} \quad (2)$$

The values of  $x_{u,max}$  for different grades of steel, obtained by applying Eq. (2), are listed in Table 1.

Table 1 Limiting depth of neutral axis for different grades of steel

Steel Grade	Fe250	Fe415	Fe500
$x_{u,max}/d$	0.5313	0.4791	0.4791

The limiting depth of neutral axis  $x_{u,max}$  corresponds to the so-called balanced section, i.e., a section that is expected to result in a 'balanced' failure at the ultimate limit state in flexure. If the neutral axis depth  $x_u$  is less than  $x_{u,max}$ , then the section is under-reinforced (resulting in a 'tension' failure); whereas if  $x_u$  exceeds  $x_{u,max}$ , it is over-reinforced (resulting in a 'compression' failure).

### Analysis of Singly Reinforced Rectangular Sections

Analysis of a given reinforced concrete section at the ultimate limit state of flexure implies the determination of the *ultimate moment  $M_{uR}$  of resistance* of the section. This is easily obtained from the couple resulting from the flexural stresses (Fig 1.9).

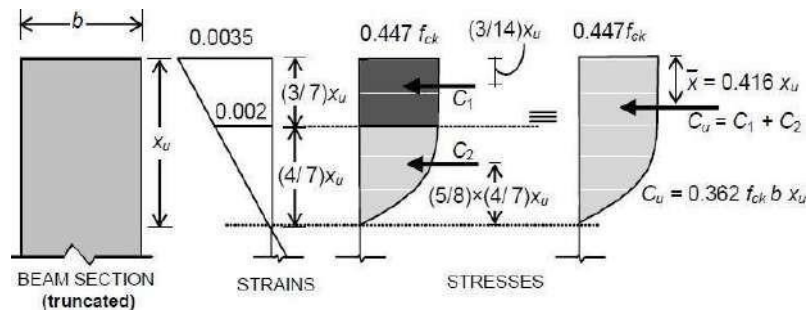

Fig. 1.9 Concrete stress-block parameters in compression

$$M_{uR} = C_u \cdot z = T_u \cdot z \quad (3)$$

where  $C_u$  and  $T_u$  are the resultant (ultimate) forces in compression and tension respectively, and  $z$  is the lever arm.

$$T_u = f_{st} \cdot A_{st} \quad (4)$$

Where  $f_{st} = 0.87 f_y$  for  $x_u \leq x_{u,max}$

and the line of action of  $T_u$  corresponds to the level of the centroid of the tension steel.

### Concrete Stress Block in Compression

In order to determine the magnitude of  $C_u$  and its line of action, it is necessary to analyse the *concrete stress block* in compression. As ultimate failure of a reinforced concrete beam in flexure occurs by the crushing of concrete, for both under- and over-reinforced beams, the shape of the compressive stress distribution ('*stress block*') at failure will be, in both cases, as shown in Fig. 1.9. The value of  $C_u$  can be computed knowing that the compressive stress in concrete is uniform at  $0.447 f_{ck}$  for a depth of  $3x_u/7$ , and below this it varies parabolically over a depth of  $4x_u/7$  to zero at the neutral axis [Fig. 1.9].

For a rectangular section of width  $b$ ,

$$C_u = 0.447 f_{ck} b \left[ \frac{3x_u}{7} + \frac{1}{3} \left( \frac{4x_u}{7} \right) \right]$$

Therefore,  $C_u = 0.361 f_{ck} b x_u$  (5)

Also, the line of action of  $C_u$  is determined by the centroid of the stress block, located at a distance  $\bar{x}$  from the concrete fibres subjected to the maximum compressive strain. Accordingly, considering moments of compressive forces  $C_1$  and  $C_2$  [Fig. 1.9] about the maximum compressive strain location,

$$(0.362f_{ck}x_u) = (0.447f_{ck}x_u) \left[ \frac{3}{7} \left( \frac{1.5x_u}{x_u} \right) + \frac{2}{7} \left( \frac{4x_u}{x_u} \right) \right] \quad (6)$$

Solving  $x_u = 0.416x_u$  (6)

### Depth of Neutral Axis

For any given section, the depth of the neutral axis should be such that  $C_u = T_u$ , satisfying equilibrium of forces. Equating  $C_u = T_u$  and  $T_u$  given by Eq. (5) and with expressions for Eq. (4) respectively.

$$x_u = \frac{0.87f_{st}A_{st}}{0.361f_{ck}b} \quad \text{valid only if resulting } x_u \leq x_{u,max} \quad (7)$$

### Ultimate Moment of Resistance

The ultimate moment of resistance  $M_{uR}$  of a given beam section is obtainable from Eq. (3).

The lever arm  $z$ , for the case of the singly reinforced rectangular section [Fig. 1.8, Fig. 1.9] is given by

$$z = d - 0.416x_u \quad (8)$$

Accordingly, in terms of the concrete compressive strength,

$$M_{uR} = 0.361f_{ck}bx_u(d - 0.416x_u) \quad \text{for all } x_u \quad (9)$$

Alternatively, in terms of the steel tensile stress,

$$M_{uR} = f_{st}A_{st}(d - 0.416x_u) \quad \text{for all } x_u \quad (10)$$

With  $f_{st} = 0.87f_y$  for  $x_u \leq x_{u,max}$

### Limiting Moment of Resistance

The limiting moment of resistance of a given (singly reinforced, rectangular) section, according to the Code (Cl. G-1.1), corresponds to the condition, defined by Eq. (2). From Eq. (9), it follows that:

$$M_{u,lim} = 0.361f_{ck}bx_{u,max}(d - 0.416x_{u,max}) \quad (11)$$

$$M_{u,lim} = 0.361f_{ck} \left( \frac{x_{u,max}}{d} \right) \left( 1 - \frac{0.416x_{u,max}}{d} \right) bd^2 \quad (11a)$$

### Limiting Percentage Tensile Steel

Corresponding to the limiting moment of resistance  $M_{u,lim}$ , there is a limiting percentage

tensile steel  $p_{t,lim} = 100 \times A_{st,lim} / bd$ . An expression for  $p_{t,lim}$  is obtainable from Eq. (7) with:

$$x_u = x_{u,max}$$

$$\frac{x_{u,max}}{d} = \frac{0.87f_y}{0.361f_{ck}} \times \frac{p_{t,lim}}{100}$$

$$\Rightarrow p_{t,lim} = 41.61 \left( \frac{f_{ck}}{f_y} \right) \left( \frac{x_{u,max}}{d} \right) \quad (12)$$

The values of  $p_{t,lim}$  and  $\frac{M_u}{bd^2}$  (in MPa units) for different combinations of steel and

concrete grades are listed in Table 2. These values correspond to the so-called 'balanced' section for a singly reinforced rectangular section.

**Table 2** Limiting values of  $p_{t,lim}$  and  $\frac{M_u}{bd^2}$  for singly reinforced rectangular beam sections for various grades of steel and concrete.

(a)  $p_{t,lim}$  values

	M20	M25	M30	M35	M40
Fe250	1.769	2.211	2.653	3.095	3.537
Fe415	0.961	1.201	1.441	1.681	1.921
Fe500	0.759	0.949	1.138	1.328	1.518

(a)  $\frac{M_{u,lim}}{bd^2}$  values (MPa)

	M20	M25	M30	M35	M40
Fe250	2.996	3.746	4.495	5.244	5.993
Fe415	2.777	3.472	4.166	4.860	5.555
Fe500	2.675	3.444	4.013	4.682	5.350

### Safety at Ultimate Limit State in Flexure

The bending moment expected at a beam section at the *ultimate limit state* due to the factored loads is called the factored moment  $M_u$ . For the consideration of various combinations of

loads (dead loads, live loads, wind loads, etc.), appropriate load factors should be applied to the specified 'characteristic' loads, and the factored moment  $M_u$  is determined by structural analysis.

The beam section will be considered to be 'safe', according to the Code, if its ultimate moment of resistance  $M_{uR}$  is greater than or equal to the factored moment  $M_u$ . In other words, for such a design, the *probability of failure* is acceptably low. It is also the intention of the Code to ensure that at ultimate failure in flexure, the type of failure should be *tension (ductile) failure*. For this reason, the Code requires the designer to ensure that

$$x_u \leq x_{u,max,W}$$

hereby it follows that, for a singly reinforced rectangular section, the tensile reinforcement percentage  $p_t$  should not exceed  $p_{t,lim}$  and the ultimate moment of resistance  $M_{uR}$  should not exceed  $M_{u,lim}$ .

### Modes of failure: Types of section

A reinforced concrete member is considered to have failed when the strain of concrete in extreme compression fibre reaches its ultimate value of 0.0035. At this stage, the actual strain in steel can have the following values:

- Equal to failure strain of steel  $\left( \frac{0.87f_y}{E_s} + 0.002 \right)$  corresponding to balanced section.
- More than failure strain, corresponding to under-reinforced section.
- Less than failure strain corresponding to over-reinforced section.

Thus for a given section, the actual value of  $\frac{x_u}{d}$  can be determined from Eq. (7). Three cases may arise.

Case-1:  $\frac{x_u}{d}$  equal to the limiting value  $\frac{x_{u,max}}{d}$ : Balanced section.

Case-2:  $\frac{x_u}{d}$  less than limiting value: under-reinforced section.

Case-3:  $\frac{x_u}{d}$  more than limiting value: over-reinforced section.

In balanced section, the strain in steel and strain in concrete reach their maximum values simultaneously. The percentage of steel in this section is known as critical or limiting steel percentage. The depth of neutral axis (NA) is  $x_u = x_{u,max}$ .

### Under-reinforced section

An under-reinforced section is the one in which steel percentage (pt) is less than critical or limiting percentage ( $p_{t,lim}$ ). Due to this the actual NA is above the balanced NA and  $x_u < x_{u,max}$ .

### Over-reinforced section

In the over reinforced section the steel percentage is more than limiting percentage due to which NA falls below the balanced NA and  $x_u > x_{u,max}$ . Because of higher percentage of steel, yield does not take place in steel and failure occurs when the strain in extreme fibres in concrete reaches its ultimate value.

### Computation of $M_u$

$M_u$  can be obtained by multiplying the tensile force  $T$  or the compressive force  $C$  with the lever arm. The expressions of  $C$ , lever arm and  $T$  are given in Eqs. (4) and (3) respectively. Previous section discusses that there are three possible cases depending on the location of  $x_u$ .

The corresponding expressions of  $M_u$  are given below for the three cases:

(i) When  $x_u < x_{u,max}$

In this case the concrete reaches 0.0035, steel has started flowing showing ductility (Strain  $> \frac{0.87f_y}{E_s} + 0.002$ ). So, the computation of  $M_u$  is to be done using the tensile force of steel in this case.

Therefore,  $M_u = T(\text{lever arm}) = 0.87f_y A_{st}(d - 0.42x_u)$

(ii) When  $x_u = x_{u,max}$

In this case steel just reaches the value of  $\frac{0.87f_y}{E_s} + 0.002$  and concrete also reaches its

maximum value. The strain of steel can further increase but the reaching of limiting strain of concrete should be taken into consideration to determine the limiting  $M_u$  as  $M_{u,lim}$  here. So, we have

$M_u = C(\text{lever arm})$

Substituting the expressions of C

$$M_{u,lim} = 0.36 x_{u,max} \left( 1 - 0.42 \frac{x_{u,max}}{d} \right) f_c b d^2$$

(iii) When  $x_u > x_{u,max}$

In this case, concrete reaches the strain of 0.0035, tensile strain of steel is much less than  $\left( \frac{0.87 f_y}{E_s} + 0.002 \right)$  and any further increase of strain of steel will mean failure of concrete,

which is to be avoided. On the other hand, when steel reaches  $\frac{0.87 f_y}{E_s} + 0.002$ , the strain of

concrete far exceeds 0.0035. Hence, it is not possible. Therefore, such design is avoided and the sections should be redesigned.

However, in case of any existing reinforced concrete beam where  $x_u > x_{u,max}$ , the moment of resistance  $M_u$  for such existing beam is calculated by restricting  $x_u$  to  $x_{u,max}$  only and the corresponding  $M_u$  will be as per the case when  $x_u = x_{u,max}$ .

### Numerical Problem

Find the moment of resistance of a singly reinforced concrete beam of 200 mm width 400 mm effective depth, reinforced with 3-16 mm diameter bars of Fe 415 steel. Take M20 grade of concrete.

#### Solution

$$A_{st} = 3 \times \frac{\pi}{4} (16)^2 = 603.19 \text{ mm}^2$$

$$\% p_t = 100 \times \frac{603.19}{200 \times 400} = 0.754\%$$

$$\frac{x_u}{d} = 2.417 p_t \frac{f_c}{f_y} = 2.417 \times \frac{0.754}{100} \times \frac{415}{20} = 0.378$$

$$\text{Now for Fe 415 grade of steel, } \frac{x_{u,max}}{d} = 0.479$$

Since the beam is under-reinforced. The moment of resistance is given by

$$\begin{aligned}
 M &= 0.87 f_y A_{st} d \left( 1 - \frac{f_y A_{st} d}{b d} \right) \\
 &= 0.87 \times 415 \times 603.19 \times 400 \left( 1 - \frac{415 \times 603.19}{20 \times 200 \times 400} \right) \\
 &= 73.48 \text{ kN-m.}
 \end{aligned}$$

### Design Type of Problems

The designer has to make preliminary plan lay out including location of the beam, its span and spacing, estimate the imposed and other loads from the given functional requirement of the structure. The dead loads of the beam are estimated assuming the dimensions  $b$  and  $d$  initially. The bending moment, shear force and axial thrust are determined after estimating the different loads. In this illustrative problem, let us assume that the imposed and other loads are given. Therefore, the problem is such that the designer has to start with some initial dimensions and subsequently revise them, if needed. The following guidelines are helpful to assume the design parameters initially.

#### (i) Selection of breadth of the beam $b$

Normally, the breadth of the beam  $b$  is governed by: (i) proper housing of reinforcing bars and (ii) architectural considerations. It is desirable that the width of the beam should be less than or equal to the width of its supporting structure like column width, or width of the wall etc. Practical aspects should also be kept in mind. It has been found that most of these requirements are satisfied with  $b$  as 150, 200, 230, 250 and 300 mm. Again, width to overall depth ratio is normally kept between 0.5 and 0.67.

#### (ii) Selection of depth of the beam $d$ and $D$

The effective depth has the major role to play in satisfying (i) the strength requirements of bending moment and shear force, and (ii) deflection of the beam. The initial effective depth of the beam, however, is assumed to satisfy the deflection requirement depending on the span and type of the reinforcement. IS 456 stipulates the basic ratios of span to effective depth of beams for span up to 10 m as (Clause 23.2.1)

Cantilever 7

Simply supported 20

Continuous 26

For spans above 10 m, the above values may be multiplied with 10/span in metres, except for cantilevers where the deflection calculations should be made. Further, these ratios are to be

multiplied with the modification factor depending on reinforcement percentage and type. Figures 4 and 5 of IS 456 give the different values of modification factors. The total depth  $D$  can be determined by adding 40 to 80 mm to the effective depth.

**(iii) Selection of the amount of steel reinforcement  $A_s$**

The amount of steel reinforcement should provide the required tensile force  $T$  to resist the factored moment  $M_u$  of the beam. Further, it should satisfy the minimum and maximum percentages of reinforcement requirements also. The minimum reinforcement  $A_{s,min}$  is provided for creep, shrinkage, thermal and other environmental requirements irrespective of the strength requirement. The minimum reinforcement  $A_{s,min}$  to be provided in a beam depends on the  $f_y$  of steel and it follows the relation: (cl. 26.5.1.1a of IS 456)

$$\frac{A_s}{bd} = \frac{0.85}{f_y}$$

The maximum tension reinforcement should not exceed  $0.04 bD$  (cl. 26.5.1.1b of IS 456), where  $D$  is the total depth.

Besides satisfying the minimum and maximum reinforcement, the amount of reinforcement of the singly reinforced beam should normally be 75 to 80% of  $p$ .

This will ensure that strain in steel will be more than  $\left(\frac{0.87f_y}{E_s} + 0.002\right)$  as the design stress in steel will be  $0.87f_y$ .

Moreover, in many cases, the depth required for deflection becomes more than the limiting depth required to resist  $M_{u,lim}$ . Thus, it is almost obligatory to provide more depth. Providing more depth also helps in the amount of the steel which is less than that required for  $M_{u,lim}$ .

This helps to ensure ductile failure. Such beams are designated as under-reinforced beams.

**(iv) Selection of diameters of bars of tension reinforcement**

Reinforcement bars are available in different diameters such as 6, 8, 10, 12, 14, 16, 18, 20, 22, 25, 28, 30, 32, 36 and 40 mm. Some of these bars are less available. The selection of the diameter of bars depends on its availability, minimum stiffness to resist while persons walk over them during construction, bond requirement etc. Normally, the diameters of main tensile bars are chosen from 12, 16, 20, 22, 25 and 32 mm.

**(v) Selection of grade of concrete**

Besides strength and deflection, durability is a major factor to decide on the grade of concrete. Table 5 of IS 456 recommends M20 as the minimum grade under mild environmental exposure and other grades of concrete under different environmental exposures also.

**(vi) Selection of grade of steel**

Normally, Fe 250, 415 and 500 are in used in reinforced concrete work. Mild steel (Fe 250) is more ductile and is preferred for structures in earthquake zones or where there are possibilities of vibration, impact, blast etc.

**Failure Modes due to Shear**



Figure 1.10(a) Webshear progress along dotted lines

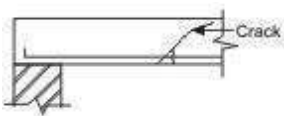

Figure 1.10(b) Flexural tension

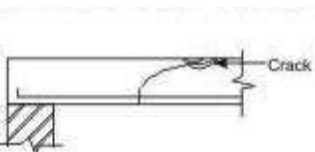

Figure 1.10 (b) Flexural compression

Bending in reinforced concrete beams is usually accompanied by shear, the exact analysis of which is very complex. However, experimental studies confirmed the following three different modes of failure due to possible combinations of shear force and bending moment at a given section:

- (i) Webshear (Fig. 1.10a)
- (ii) Flexural tension shear (Fig. 1.10b)
- (iii) Flexural compression shear (Fig. 1.10c)

Web shear causes cracks which progress along the dotted line shown in Fig. 1.10a. Steel yields in flexural tension shear as shown in Fig. 1.10b, while concrete crushes in compression due to flexural compression shear as shown in Fig. 1.10c. An in-depth presentation of the

three types of failure modes is beyond the scope here. Only the salient points needed for the routine design of beams in shear are presented here.

### Shear Stress

The distribution of shear stress in reinforced concrete rectangular, *T* and *L*-beams of uniform and varying depths depends on the distribution of the normal stress. However, for the sake of simplicity the nominal shear stress  $\tau_v$  is considered which is calculated as follows (IS 456, cl. 40.1 and 40.1.1):

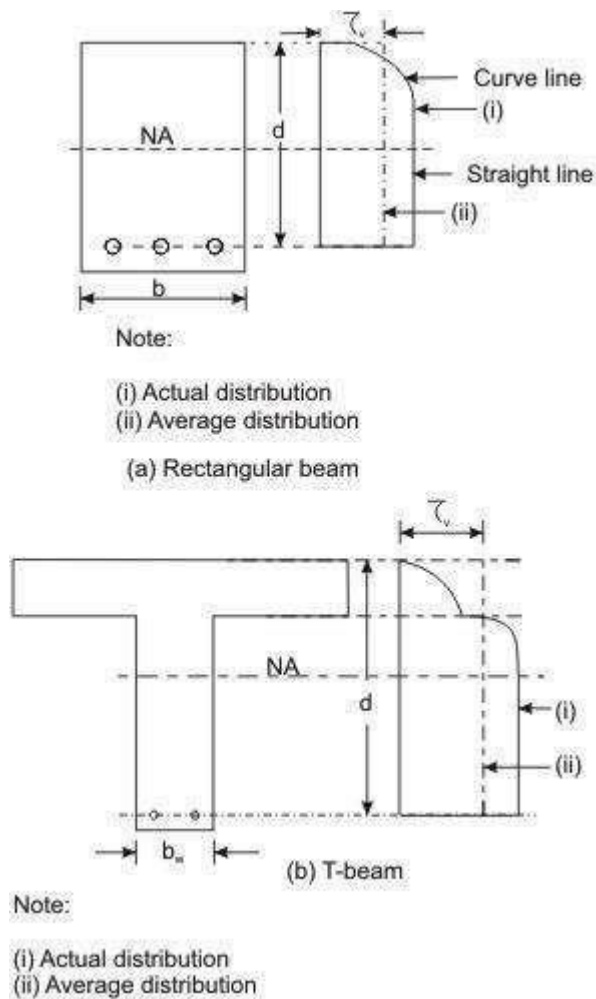

Figure 1.11: Distribution of shear stress and average shear stress

(i) In beams of uniform depth (Figs. 1.11a and b):

$$\tau_v = \frac{V_u}{bd} \quad (13)$$

where  $V_u$  = shear force due to design loads,

$b$  = breadth of rectangular beams and breadth of the web  $b_w$  for flanged beams, and

$d$ =effectivedepth.

(ii) Inbeams ofvaryingdepth:

$$\tau_v = \frac{V_u \pm \frac{M_u \tan \beta}{d}}{bd} \quad (14)$$

where  $\tau_v$ ,  $V_u$ ,  $b$ ,  $d$  and  $d$  arethesameasin(i),

$M_u$ =bending momentatthesection,and

$\beta$ = angle between the top and the bottom edges.

The positive sign is applicable when the bending moment  $M$  decreases numerically in the same direction as the effective depth increases, and the negative sign is applicable when the bending moment  $M$  increases numerically in the same direction as the effective depth increases.

### Design Shear Strength of Reinforced Concrete

Recent laboratory experiments confirmed that reinforced concrete in beams has shear strength even without any shear reinforcement. This shear strength ( $\tau$ ) depends on the grade of concrete and the percentage of tension steel in beams. On the other hand, the shear strength of reinforced concrete with reinforcement is restricted to some maximum value  $\tau_{cmax}$  depending on the grade of concrete. These minimum and maximum shear strengths of reinforced concrete (IS 456, cl. 40.2.1 and 40.2.3, respectively) are given below:

#### Design shear strength without shear reinforcement (IS 456, cl. 40.2.1)

Table 19 of IS 456 stipulates the design shear strength of concrete  $\tau$  for different grades of concrete with a wide range of percentages of positive tensile steel reinforcement. It is worth mentioning that the reinforced concrete beams must be provided with the minimum shear reinforcement as per cl. 40.3 even when  $\tau$  is less than  $\tau_c$  given in Table 3.

Table 3 Design shear strength of concrete,  $\tau_c$  in N/mm<sup>2</sup>

$100A_s/bd$	Grade of concrete				
	M20	M25	M30	M35	M40 and above
$\leq 0.15$	0.28	0.29	0.29	0.29	0.30
0.25	0.36	0.36	0.37	0.37	0.38
0.50	0.48	0.49	0.50	0.50	0.51
0.75	0.56	0.57	0.59	0.59	0.60

1.00	0.62	0.64	0.66	0.67	0.68
1.25	0.67	0.70	0.71	0.73	0.74
1.50	0.72	0.74	0.76	0.78	0.79
1.75	0.75	0.78	0.80	0.82	0.84
2.00	0.79	0.82	0.84	0.86	0.88
2.25	0.81	0.85	0.88	0.90	0.92
2.50	0.82	0.88	0.91	0.93	0.95
2.75	0.82	0.90	0.94	0.96	0.98
≥3.00	0.82	0.92	0.96	0.99	1.01

In Table 3,  $A_s$  is the area of longitudinal tension reinforcement which continues at least one effective depth beyond the section considered except at support where the full area of tension reinforcement may be used provided the detailing is as per IS 456, cls. 26.2.2 and 26.2.3.

**Maximum shear stress  $\tau_{c,max}$  with shear reinforcement (cls. 40.2.3, 40.5.1 and 41.3.1)**

Table 20 of IS 456 stipulates the maximum shear stress of reinforced concrete in beams  $\tau_{c,max}$  as given below in Table 6.2. Under no circumstances, the nominal shear stress in beams  $\tau_v$  shall exceed  $\tau_{c,max}$  given in Table 6.2 for different grades of concrete.

Table 4 Maximum shear stress,  $\tau_{c,max}$  in  $N/mm^2$

Grade of concrete	M20	M25	M30	M35	M 40 and above
$\tau_{c,max} N/mm^2$	2.8	3.1	3.5	3.7	4.0

**Critical Section for Shear**

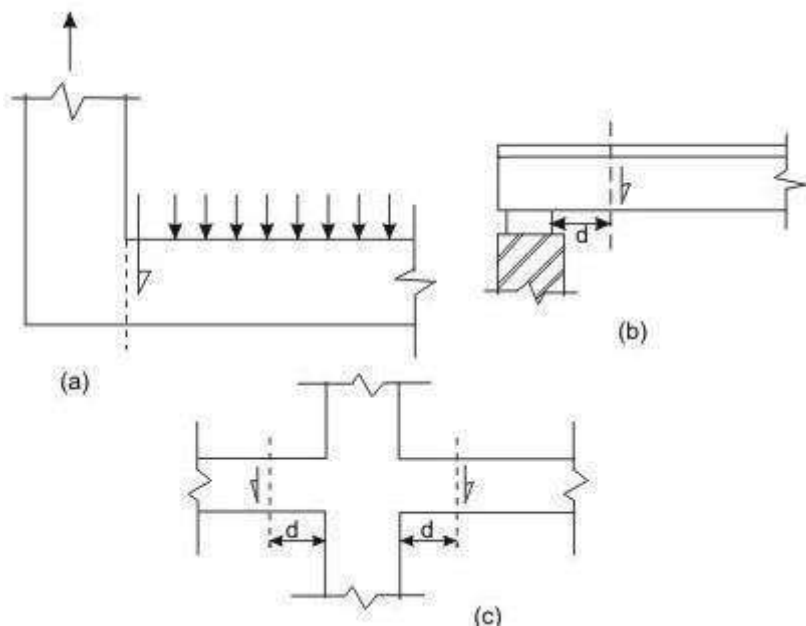

Figure 1.12 Support condition for locating factored shear force

Clauses 22.6.2 and 22.6.2.1 stipulate the critical section for shear and areas follows:

For beams generally subjected to uniformly distributed loads or where the principal load is located further than  $2d$  from the face of the support, where  $d$  is the effective depth of the beam, the critical sections depend on the conditions of supports as shown in Figs. 1.12 a, b and c and are mentioned below.

(i) When the reaction in the direction of the applied shear introduces tension (Fig. 1.12a) into the end region of the member, the shear force is to be computed at the face of the support of the member at that section.

(ii) When the reaction in the direction of the applied shear introduces compression into the end region of the member (Figs. 1.12b and c), the shear force computed at a distance  $d$  from the face of the support is to be used for the design of sections located at a distance less than  $d$  from the face of the support. The enhanced shear strength of sections close to supports, however, may be considered as discussed in the following section.

**Minimum Shear Reinforcement (cls. 40.3, 26.5.1.5 and 26.5.1.6 of IS 456)**

Minimum shear reinforcement has to be provided even when  $\tau_v$  is less than  $\tau_c$  given in Table 3

as recommended in cl. 40.3 of IS 456. The amount of minimum shear reinforcement, as given in cl. 26.5.1.6, is given below.

The minimum shear reinforcement in the form of stirrups shall be provided such that:

$$\frac{A_{sv}}{bs_v} \geq \frac{0.4}{0.87f_y} \tag{15}$$

where  $A_{sv}$  = total cross-sectional area of stirrup leg effective in shear,

$s_v$  = stirrup spacing along the length of the member,

$b$  = breadth of the beam or breadth of the web of the web of flanged beam  $b_w$ , and

$f_y$  = characteristic strength of the stirrup reinforcement in N/mm<sup>2</sup> which shall not be taken greater than 415 N/mm<sup>2</sup>.

The above provision is not applicable for members of minor structural importance such as lintels

where the maximum shear stress calculated is less than half the permissible

value. The minimum shear reinforcement is provided for the following:

(i) Any sudden failure of beams is prevented if concrete cover bursts and the bond to the tension steel is lost.

(ii) Brittle shear failure is arrested which would have occurred without shear reinforcement.

- (iii) Tension failure is prevented which would have occurred due to shrinkage, thermal stresses and internal cracking in beams.
- (iv) To hold the reinforcement in place when concrete is poured.
- (v) Section becomes effective with the tie effect of the compression steel.

Further, cl. 26.5.1.5 of IS 456 stipulates that the maximum spacing of shear reinforcement measured along the axis of the members shall not be more than  $0.75d$  for vertical stirrups and

$d$  for inclined stirrups at  $45^\circ$ , where  $d$  is the effective depth of the section. However, the spacing shall not exceed 300 mm in any case.

### Design of Shear Reinforcement (cl.40.4 of IS 456)

When  $\tau_v$  is more than  $\tau_c$  given in Table 6.1, shear reinforcement shall be provided in any of the three following forms:

- (a) Vertical stirrups,
- (b) Bent-up bars along with stirrups, and
- (c) Inclined stirrups.

In the case of bent-up bars, it is to be seen that the contribution towards shear resistance of bent-up bars should not be more than fifty percent of that of the total shear reinforcement. The amount of shear reinforcement to be provided is determined to carry a shear force  $V$

equal to

$$V_{us} = V_u - \tau_c b d \quad (16)$$

where  $b$  is the breadth of rectangular beams or  $b_w$  in the case of flanged beams.

The strengths of shear reinforcement  $V_{us}$  for the three types of shear reinforcement are as follows:

- (a) Vertical stirrups:

$$V_{us} = \frac{0.87 f_y A_{sv} d s_v}{s_v} \quad (17)$$

- (b) For inclined stirrups or a series of bars bent-up at different cross-sections:

$$V_{us} = \frac{0.87 f_y A_{sv} d}{s_v} (\sin \alpha + \cos \alpha) \quad (18)$$

- (c) For single bar or single group of parallel bars, all bent-up at the same cross-section:

$$V_{us} = 0.87 f_y A_{sv} d \sin \alpha \quad (19)$$

where  $A_{sv}$  = total cross-sectional area of stirrup legs or bent-up bars within a distance  $s$ ,

$s$  = spacing of stirrups or bent-up bars along the length of the member,

$\tau_v$  = nominal shear stress,

$\tau_c$  = design shear strength of concrete,

$b$  = breadth of the member which for the flanged beam shall be taken as the breadth of the web  $b_w$ ,

$f_y$  = characteristic strength of the stirrup or bent-up reinforcement which shall not be taken greater than 415 N/mm<sup>2</sup>,

$\alpha$  = angle between the inclined stirrup or bent-up bar and the axis of the member, not less than 45°, and

$d$  = effective depth.

The following two points are to be noted:

- (i) The total shear resistance shall be computed as the sum of the resistance for the various types separately where more than one type of shear reinforcement is used.
- (ii) The area of stirrups shall not be less than the minimum specified in cl.

#### 26.5.1.6. Curtailment of Tension Reinforcement in Flexural Members (cl. 26.2.3.2 of IS

**456**) Curtailment of tension reinforcement is done to provide the required reduced area of steel with the reduction of the bending moment. However, shear force increases with the reduction of bending moment. Therefore, it is necessary to satisfy any one of the following three conditions while terminating the flexural reinforcement in tension zone:

- (i) The shear stress  $\tau_v$  at the cut-off point should not exceed two-thirds of the permitted value

which includes the shear strength of the web reinforcement. Accordingly,

$$\tau_v \leq (2/3)(\tau_c + V_{us}/bd)$$

$$\text{or } V_{us} \geq (1.5\tau_v - \tau_c)bd$$

- (ii) For each of the terminated bars, additional stirrups should be provided over a distance of three-fourths of the effective depth from the cut-off point. The additional stirrups shall not be less than  $0.4b_s/f_y$ , where  $b_s$  is the breadth of rectangular beams and is replaced by  $b_w$ , the breadth of the web for flanged beams,  $s$  = spacing of additional stirrups and  $f_y$  is the

characteristic strength of stirrup reinforcement in N/mm<sup>2</sup>. The value of  $s$  shall not exceed  $d/8$

$\beta$ ), where  $\beta$  is the ratio of area of bars cut-off to the total area of bars at that section, and  $d$  is the effective depth.

(iii) For bars of diameters 36 mm and smaller, the continuing bars provide double the area required for flexure at the cut-off point. The shear stress should not exceed three-fourths that permitted. Accordingly,

$$\tau_v \leq (3/4)(\tau_c + V_{us}/bd)$$

$$\text{or } V_{us} \geq (1.33\tau_v - \tau_c)bd$$

In the above expression  $b$  is the breadth of the rectangular beams which will be  $b$  in the case of flanged beams.

### Bond

The bond between steel and concrete is very important and essential so that they can act together without any slip in a loaded structure. With the perfect bond between them, the plane section of a beam remains plane even after bending. The length of a member required to develop the full bond is called the anchorage length. The bond is measured by bond stress. The local bond stress varies along a member with the variation of bending moment.

Thus, a tensile member has to be anchored properly by providing additional length on either side of the point of maximum tension, which is known as ‘Development length in tension’.

Similarly, for compression members also, we have ‘Development length in compression’.

Accordingly, IS

456, cl. 26.2 stipulates the requirements of proper anchorage of reinforcement in terms of development length  $L_d$  only employing design bond stress  $\eta$ .

### Design bond stress – values

The average bond stress is still used in the working stress method and IS 456 has mentioned about it in cl. B-2.1.2. However, in the limit state method of design, the average bond stress has been designated as design bond stress  $\tau_{bd}$  and the values are given in cl. 26.2.1.1. The same is given below as ready reference.

Table 5:  $\eta$  for plain bars in tension

Grade of concrete	M20	M25	M30	M35	M40 and above
Design Bond Stress $\tau_{bd}$ in N/mm <sup>2</sup>	1.2	1.4	1.5	1.7	1.9

For deformed bars conforming to IS 1786, these values shall be increased by 60 per cent. For bars in compression, the values of bond stress in tension shall be increased by 25 percent.

## Development Length

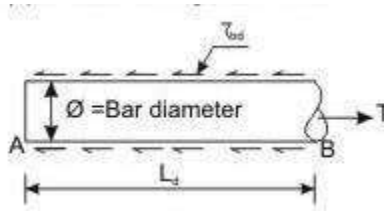

Figure 1.13 Development length of bar

Figure 1.13 shows the free body diagram of the segment AB of the bar. At B, the tensile force  $T$  trying to pull out the bar is of the value  $T = \pi \theta \zeta_s / 4$ , where  $\theta$  is the nominal diameter of the bar and  $\zeta_s$  is the tensile stress in bar at the section considered at design loads. It is necessary to have the resistance force to be developed by  $\eta_{bd}$  for the length  $L$  to overcome the tensile force. The resistance force =  $\pi \theta (L) (\eta_{bd})$ . Equating the two, we get

$$\pi \theta (L) (\eta_{bd}) = \pi \theta \zeta_s / 4 \quad (19)$$

Equation (19), thus gives

$$L = \frac{\phi \sigma_s}{4 \tau_{bd}} \quad (20)$$

The above equation is given in cl. 26.2.1 of IS 456 to determine the development length of bars.

The example taken above considers round bar in tension. Similarly, other sections of the bar should have the required  $L_d$  as determined for such sections. For bars in compression, the development length is reduced by 25 per cent as the design bond stress in compression  $\eta_{bd}$  is 25 per cent more than that in tension (see the last lines below Table 6.4). Following the same logic, the development length of deformed bars is reduced by 60 per cent of that needed for the plain round bars. Tables 64 to 66 of SP-16 present the development lengths of fully stressed plain and deformed bars (when  $\zeta_s = 0.87 f_y$ ) both under tension and compression. It is to be noted that the consequence of stress concentration at the lugs of deformed bars has not been taken into consideration.

### Checking of Development Lengths of Bars in Tension

The following are the stipulation of cl. 26.2.3.3 of IS 456.

- (i) At least one-third of the positive moment reinforcement in simple members and one-fourth of the positive moment reinforcement in continuous members shall be extended along the same face of the member into the support, to a length equal to  $L_d / 3$ .

(ii) Such reinforcements of (i) above shall also be anchored to develop its design stress intensity at the face of the support, when such member is part of the primary lateral load resisting system.

(iii) The diameter of the positive moment reinforcement shall be limited to a diameter such that the  $L_d$  computed for  $\zeta = f_s$  in Eq. (20) does not exceed the following:

$$(L_d) \leq \frac{M_1 + L}{\sigma_s} \quad (21)$$

when  $\sigma_s = f_d$

where  $M_1$  = moment of resistance of the section assuming all reinforcement at the section to be stressed to  $f_d$ ,

$f_d = 0.87 f_y$ ,

$V$  = shear force at the section due to design loads,

$L$  = sum of the anchorage beyond the centre of the support and the equivalent

anchorage value of any hook or mechanical anchorage at simple support.

At a point of inflection,  $L$  is limited to the effective depth of the member or

$12\theta$ , whichever is greater, and  $\theta$

= diameter of bar.

It has been further stipulated that  $M/V$  in the above expression may be increased by 30 per cent when the ends of the reinforcement are confined by a compressive reaction.

### **Numerical problem of design of singly reinforced beam**

A reinforced concrete beam is supported on two walls 250mm thick, spaced at a clear distance of 6m. The beam carries a super-imposed load of 9.8 KN/m. design the beam using M20 concrete and HYSD bars of Fe415 grade.

Solution

The minimum depth of beam is based on limit state of serviceability requirements.

As per IS 456:2000 clno 23.2.1(a), for

simply supported beam  $l/d = 20$  and for balanced section,  $p_{t,lim} = 0.96\%$

Also for Fe415 steel,  $f_s = 0.58 \times 415 = 240 \text{ N/mm}^2$

As per IS 456:2000 clno 23.2.1(c) and fig 4 of IS 456:2000 modification

factor = 1. Therefore,  $l/d = 20 \times 1 \Rightarrow d = l/20 = 6000/20 = 300$

This is the minimum value of  $d$ . actual value of  $d$ , based on bending may be more than this.

Now from experience, assumed  $d = l/15 = 400 \text{ mm}$

Therefore, overall depth = effective depth + clear cover + diameter of stirrup + 0.5(diameter of main reinforcement)

$$= 400 + 25 + 8 + 0.5 \times 20 = 443 \text{ mm} \approx 450 \text{ mm}$$

Assume  $b = 250 \text{ mm}$

Therefore, try a trial section of dimension  $250 \times 450$ . Load

#### dCalculation

Self-weight of beam (DL) =  $0.25 \times 0.45 \times 1 \times 25 = 2.8125$

KN/m Super-imposed load (LL) =  $9.8 \text{ KN/m}$

Therefore, total load,  $w = (\text{DL} + \text{LL}) = (2.8125 + 9.8) = 12.6125$

KN/m Design load,  $w_u = 1.5 \times w = 18.9187 \text{ KN/m}$

#### Calculation of effective span

As per IS 456:2000, clno 22.2(a), the effective span of a simply supported beam is lesser of the following two.

Clear span + the effective depth of beam or slab Or

centre to centre distance between

supports. Clear span =  $6 \text{ m}$

Effective depth of beam,  $d = 450 - 25 - 8 - 0.5 \times 20 = 407 \text{ mm}$

Therefore, clear span + effective depth of

beam =  $(6 + 0.407) \text{ m} = 6.407 \text{ m}$  Centre to centre distance between support =  $(6 +$

$0.25/2 + 0.25/2) \text{ m} = 6.25 \text{ m}$  Lesser of two =  $6.25 \text{ m}$

Therefore, effective span =  $6.25 \text{ m}$

#### Calculation of BM and SF

$$\text{Maximum BM} = \frac{w_u l^2}{8} = \frac{18.9187 \times 6.25^2}{8} = 92.376 \text{ KN} \cdot \text{m}$$

$$\text{Maximum SF} = \frac{w_u l}{2} = \frac{18.9187 \times 6.25}{2} = 59.12 \text{ KN}$$

Computation of effective depth,  $d$

For M20 grade of concrete and Fe415 grade of steel

$$M_u = 0.138 f_{ck} b d^2$$

$$\text{Therefore, } d = \sqrt{\frac{92.376 \times 10^6}{0.138 \times 20 \times 250}} = 365.89 \text{ mm}$$

Now assumed depth was = 407 mm Therefore

$$f_{\text{required}} < a_{\text{assumed}}$$

So, the section assumed is safe from bending moment point of view.

Since the available depth (407 mm) is greater than required depth (365.89 mm). So the section is under reinforced.

Calculation of steel reinforcement

The reinforcement for an under-reinforced section is given by

$$A_{st} = \frac{0.5 f_{ck} \left[ 1 - \sqrt{1 - \frac{4.6 M_u}{f_{ck} b d^2}} \right]}{f_y} = \frac{0.5 \times 20 \left[ 1 - \sqrt{1 - \frac{4.6 \times 92.376 \times 10^6}{20 \times 250 \times 407^2}} \right]}{250} = 740.88 \text{ mm}^2$$

$$A_{st} = 740.88 \text{ mm}^2$$

$$\% p_t = 100 \frac{740.88}{250 \times 407} = 0.728\% < p_{t, \text{lim}}$$

$$\text{Therefore, using 20 mm dia, no of bars required} = \frac{740.88}{\frac{\pi (20)^2}{4}} = 2.35 \approx 3.$$

Provide 3 nos 20 diameter

bar. Shear Reinforcement

As per IS 456:2000 Cl. No. 22.6.2, the critical section for shear is at a distance of  $\frac{d}{2}$  from the face of the support.

So, shear force at that distance,  $V_u = 59.12 - 18.9187(0.25/2 + 0.407) = 49.05 \text{ KN}$ .

$$\tau_v = \frac{V_u}{b d} = \frac{49.05 \times 10^3}{250 \times 407} = 0.482 \text{ N/mm}^2$$

Nominal shear stress,  $\tau_v = 0.482 \text{ N/mm}^2$

$$\% p_{at\ support} = 100 \times \frac{\pi \cdot 3 \times (20)^2}{4 \cdot 250 \times 407} = 0.926\%$$

As per IS 456:2000, table 19, the design shear strength of concrete,  $\tau_c$  for  $\% p_t = 0.926$  and M20 grade of concrete,  $\tau_c = 0.61 \text{ N/mm}^2$

Since  $\tau_v < \tau_c$ , no shear reinforcement is necessary. However, minimum shear reinforcement as per cl no 26.5.1.6 of IS 456:2000 should be provided.

$$\frac{A_{sv}}{bS_v} \geq \frac{0.4}{0.87f_y} \Rightarrow S_v = \frac{2.175 A_{sv} f_y}{b}$$

As per cl no 26.5.1.5 of IS 456:2000, maximum spacing of shear reinforcement least of the following

(a) 0.75d or (b) 300mm

Hence provide 2<sup>L</sup>-8mm diameter @ 300mm c/c throughout the length of the beam. Check for Development length

As per cl no 26.2.1 of IS 456:2000, the development length  $L_d$  is given by

$$L_d = \frac{\phi \sigma_s}{4 \tau_{bd}}$$

$\tau_{bd} = 1.2 \text{ N/mm}^2$  for M20 grade of concrete.

For deformed bars conforming to IS 1786 these values shall be increased by 60%.

$$L_d = \frac{\phi \sigma_s}{(4 \tau_{bd}) \times 1.6} = \frac{20 \times 0.87 \times 415}{4 \times 1.2 \times 1.6} = 940.23 \text{ mm}$$

Now as per cl no 26.2.3.3 (c) of IS 456:2000, at a simple support and at points of inflection, positive moment tension reinforcement shall be limited to a diameter such that  $L_d$  computed for  $d$  does not exceed

$$\frac{M_1 + L V}{0}$$

The value of  $\frac{M_1}{V}$  in the above expression may be increased by 30% when the ends of the

reinforcement are confined by a compressive reaction.

$$L \leq 1.3 \frac{M_1 + L}{d} \frac{M_1 + L}{V} \quad 0$$

3 bars are available at supports.

$$x = \frac{0.87 f_y A_{st}}{0.36 f_{ck} b} = \frac{0.87 \times 415 \times (3 \times 314.15)}{0.36 \times 20 \times 250} = 189 \text{ mm}$$

$$\begin{aligned} M_1 &= 0.87 f_y A_{st} (d - 0.416 x_u) \\ &= 0.87 \times 415 \times (3 \times 314.15) (407 - 0.416 \times 189) \\ &= 111.73 \text{ KN-m} \end{aligned}$$

$$V = 59.12 \text{ KN}$$

$L_0 =$  greatest of effective depth of member or  $12\phi$

$$= 407 \text{ mm}$$

$$1.3 \frac{M_1 + L}{d} \frac{M_1 + L}{V} = 2.863 \text{ m}$$

Therefore,  $L \leq 1.3 \frac{M_1 + L}{d} \frac{M_1 + L}{V} \quad 0$

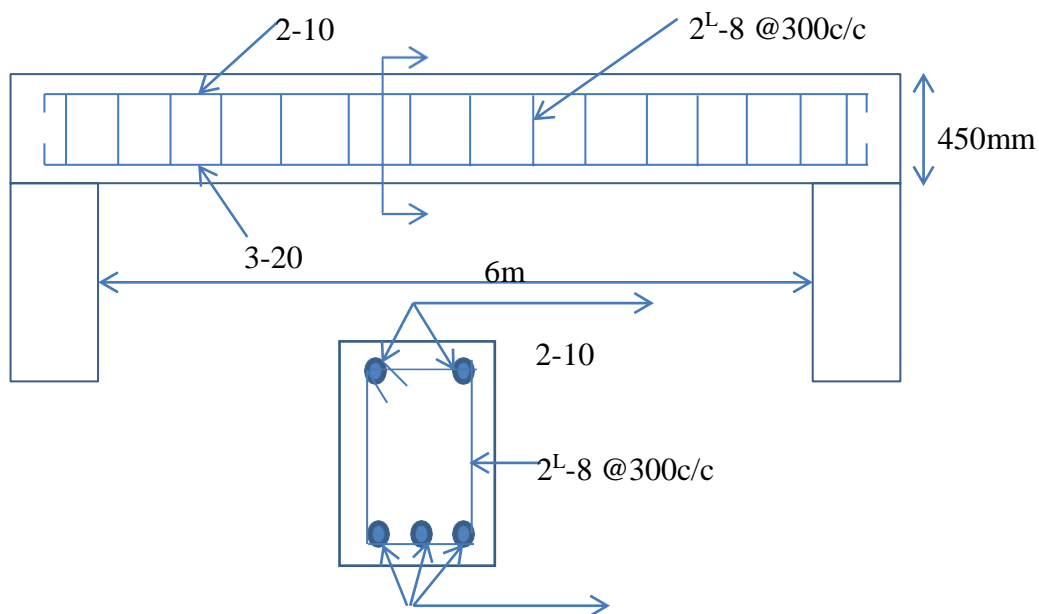

Reinforcement Detailing

# MODULE-2

## One-way and Two-way Slabs

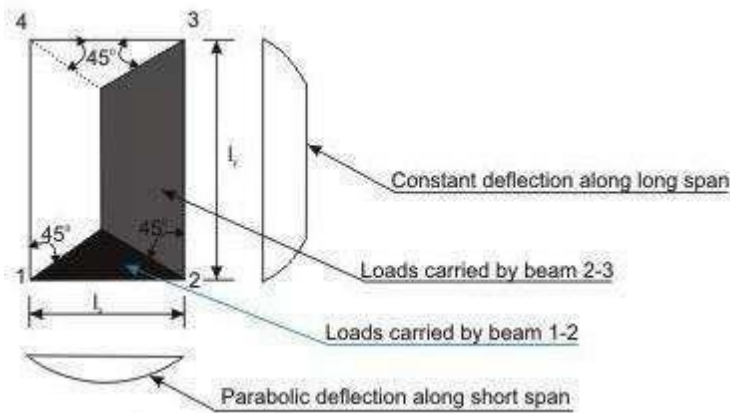

Figure 2.1(a) One-way slab ( $l_y/l_x > 2$ )

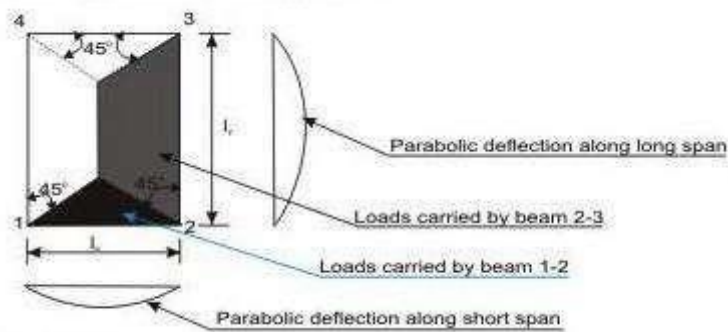

Figure 2.1(b) Two-way slab ( $l_y/l_x \leq 2$ )

Figures 2.1a and b explain the share of loads on beams supporting solid slabs along four edges when vertical loads are uniformly distributed. It is evident from the figures that the

share of loads on beams in two perpendicular directions depends upon the aspect ratio  $l_y/l_x$

of the slab,  $l_x$  being the shorter span. For large values of  $l_y$ , the triangular area is much less

than the trapezoidal area (Fig. 2.1a). Hence, the share of loads on beams along shorter span will gradually reduce with increasing ratio of  $l_y/l_x$ . In such cases, it may be said that the loads

are primarily taken by beams along longer span. The deflection profiles of the slab along

both directions are also shown in the figure. The deflection profile is found to be

constant along the longer span except near the edges for the slab panel of Fig. 2.1a. These slabs are designated as one-way slabs as they span in one direction (shorter one) only

for a large part of the slab when  $l_y/l_x > 2$ .

On the other hand, for square slabs of  $l_y/l_x = 1$  and rectangular slabs of  $l_y/l_x$  up to 2, the deflection profiles in the two directions are parabolic (Fig. 2.1b). Thus, they are spanning in

two directions and these slabs with  $l_y/l_x$  up to 2 are designated as two-way slabs, when supported on all edges.

It would be noted that an entirely one-way slab would need lack of support on short edges. Also, even for  $l_y/l_x < 2$ , absence of supports in two parallel edges will render the slab one-way. In Fig. 2.1b, these separating line at 45 degree is tentative serving purpose of design. Actually, this angle is a function of  $l_y/l_x$ .

### Design of One-way Slabs

The procedure of the design of one-way slab is the same as that of beams. However, the amount of reinforcing bars are for one metre width of the slab as to be determined from either the governing design moments (positive or negative) or from the requirement of minimum reinforcement. The different steps of the design are explained below.

#### Step 1: Selection of preliminary depth of slab

The depth of the slab shall be assumed from the span to effective depth ratio.

#### Step 2: Design loads, bending moments and shear forces

The total factored (design) loads are to be determined adding the estimated dead load of the slab, load of the floor finish, given or assumed live loads etc. after multiplying each of them with the respective partial safety factors. Thereafter, the design positive and negative bending moments and shear forces are to be determined using the respective coefficients given in Tables 12 and 13 of IS 456.

#### Step 3: Determination/checking of the effective and total depths of slabs

The effective depth of the slab shall be determined employing.

$$M_{u,lim} = R_{s,lim} b d^2$$

The total depth of the slab shall then be determined adding appropriate nominal cover (Table 16 and 16A of cl.26.4 of IS 456) and half of the diameter of the larger bar if the bars are of different sizes. Normally, the computed depth of the slab comes out to be much less than the assumed depth in Step 1. However, final selection of the depth shall be done after checking the depth for shear force.

#### Step 4: Depth of the slab for shear force

Theoretically, the depth of the slab can be checked for shear force if the design shear strength of concrete is known. Since this depends upon the percentage of tensile reinforcement, the design

shear strength shall be assumed considering the lowest percentage of steel. The value of  $\tau_c$  shall be modified after knowing the multiplying factor  $k$  from the depth tentatively selected for the slab. Step 3. If necessary, the depth of the slab shall be modified.

#### Step 5: Determination of area of steel

Area of steel reinforcement along the direction of one-way slab should be determined employing the following Eq.

$$M_u = 0.87 f_{yk} A_{st} \left\{ 1 - \frac{A_{st} f_{yk}}{b d f_{ctk}} \right\}$$

The above equation is applicable as the slab in most of the cases is under-reinforced due to the selection of depth larger than the computed value in Step 3. The area of steel so determined should be checked whether it is at least the minimum area of steel as mentioned in cl. 26.5.2.1 of IS 456.

#### Step 6: Selection of diameters and spacings of reinforcing bars (cls. 26.5.2.2 and 26.3.3 of IS 456)

The diameter and spacing of bars are to be determined as per cls. 26.5.2.2 and 26.3.3 of IS 456. As mentioned in Step 5, this step may be avoided when using the tables and charts of SP-16.

Design the one-way continuous slab of Fig. 8.18.6 subjected to uniformly distributed imposed loads of  $5 \text{ kN/m}^2$  using M20 and Fe415. The load of floor finish is  $1 \text{ kN/m}^2$ . The span dimensions shown in the figure are effective spans. The width of beams at the support = 300 mm.

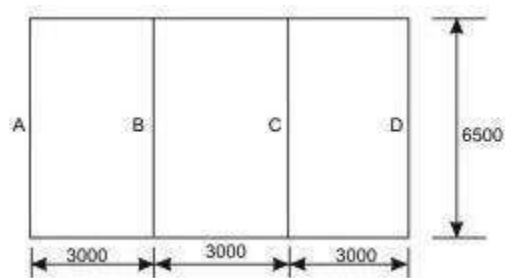

#### Step 1: Selection of preliminary depth of slab

The basic value of span to effective depth ratio for the slab having simple support at the end and continuous at the intermediate is  $(20+26)/2=23$  (cl. 23.2.1 of IS 456).

Modification factor with assumed  $p=0.5$  and  $f_s = 240 \text{ N/mm}^2$  is obtained as 1.18 from Fig. 4 of IS 456.

Therefore, the minimum effective depth  $= 3000/23(1.18) = 110.54 \text{ mm}$ . Let us take the effective depth  $d = 115 \text{ mm}$  and with 25 mm cover, the total depth  $D = 140 \text{ mm}$ .

### Step 2: Design loads, bending moment and shear force

Dead loads of slab of 1 m width  $= 0.14(25) = 3.5$

kN/m Dead load of floor finish  $= 1.0 \text{ kN/m}$

Factored dead load  $= 1.5(4.5) = 6.75$

kN/m Factored live load  $= 1.5(5.0) = 7.50$

kN/m Total factored load  $= 14.25 \text{ kN/m}$

Maximum moments and shear are determined from the coefficients given in Tables 12 and 13 of IS 456.

Maximum positive moment  $= 14.25(3)(3)/12 = 10.6875 \text{ kNm/m}$

Maximum negative moment  $= 14.25(3)(3)/10 = 12.825 \text{ kNm/m}$

Maximum shear  $V_u = 14.25(3)(0.4) = 17.1 \text{ kN}$

### Step 3: Determination of effective and total depth of slab

From Eq.  $M_{u,lim} = R_{lim} b d^2$  where  $R_{lim}$  is  $2.76 \text{ N/mm}^2$ . So,  $d = \left\{ \frac{12.825(10)}{(2.76)(1000)} \right\}^{0.5} = 68.17 \text{ mm}$

Since, the computed depth is much less than that determined in Step 1, let us keep  $D = 140 \text{ mm}$  and  $d = 115 \text{ mm}$ .

### Step 4: Depth of slab for shear force

Table 19 of IS 456 gives  $\tau_c = 0.28 \text{ N/mm}^2$  for the lowest percentage of steel in the slab.

Further for the total depth of 140 mm, let us use the coefficient  $k$  of cl. 40.2.1.1 of IS 456 as 1.3 to get  $\tau_c = k\tau_c = 1.3(0.28) = 0.364 \text{ N/mm}^2$ .

Table 20 of IS 456 gives  $\tau_{c,max} = 2.8 \text{ N/mm}^2$ . For this problem  $\tau_v = \frac{V_u}{bd} = \frac{17.1}{115} = 0.148 \text{ N/mm}^2$ . Since,  $\tau_v < \tau_c < \tau_{c,max}$ , the effective depth  $d = 115 \text{ mm}$  is

acceptable.

### Step 5: Determination of area of steel

It is known that

$$M_u = 0.87 f_{yk} A_{st} \left\{ 1 - \frac{A_{st} f_{yk}}{f_{ct} b d} \right\}$$

(i) For the maximum negative bending moment

$$12825000 = 0.87 (415) A_{st} (115) \left\{ 1 - \frac{A_{st} (415)}{(1000) (115) (20)} \right\}$$

$$\text{or } -5542.16 A_{st}^2 + 1711871.646 A_{st} = 0$$

Solving the quadratic equation, we have the negative  $A_{st} = 328.34 \text{ mm}^2$

(ii) For the maximum positive bending moment

$$10687500 = 0.87 (415) A_{st} (115) \left\{ 1 - \frac{A_{st} (415)}{(1000) (115) (20)} \right\}$$

$$\text{or } -5542.16 A_{st}^2 + 1426559.705 A_{st} = 0$$

Solving the quadratic equation, we have the positive  $A_{st} = 270.615 \text{ mm}^2$

### Distribution steel bars along longer span

Distribution steel area = Minimum steel area =  $0.12 (1000) (140) / 100 = 168 \text{ mm}^2$ . Since, both positive and negative areas of steel are higher than the minimum area, we provide:

(a) For negative steel: 10 mm diameter bars @ 230 mm/c for which  $A_{st} = 341 \text{ mm}^2$   
giving  $p = 0.2965$ .

(b) For positive steel: 8 mm diameter bars @ 180 mm/c for which  $A_{st} = 279 \text{ mm}^2$   
giving  $p = 0.2426$

(c) For distribution steel: Provide 8 mm diameter bars @ 250 mm/c for which  $A_{st}$  (minimum) = 201 mm<sup>2</sup>.

### Step 6: Selection of diameter and spacing of reinforcing bars

The diameter and spacing already selected in step 5 for main and distribution bars are checked below:

For main bars (cl. 26.3.3.b.1 of IS 456), the maximum spacing is the lesser of  $3d$  and 300 mm i.e., 300 mm. For distribution bars (cl. 26.3.3.b.2 of IS 456), the maximum spacing is the lesser of  $5d$  or 450 mm i.e., 450 mm. Provided spacings, therefore, satisfy the requirements.

Maximum diameter of the bars (cl. 26.5.2.2 of IS 456) shall not exceed  $140/8 = 17 \text{ mm}$  is also satisfied with the bar diameters selected here.

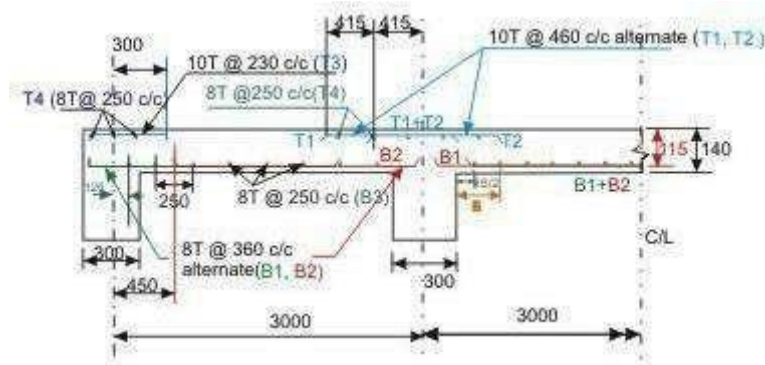

## Two-way Slabs

Two-way slabs subjected mostly to uniformly distributed loads resist them primarily by bending about both the axis. However, as in the one-way slab, the depth of the two-way slabs should also be checked for the shear stresses to avoid any reinforcement for shear. Moreover, these slabs should have sufficient depth for the control deflection. Thus, strength and deflection are the requirements of design of two-way slabs.

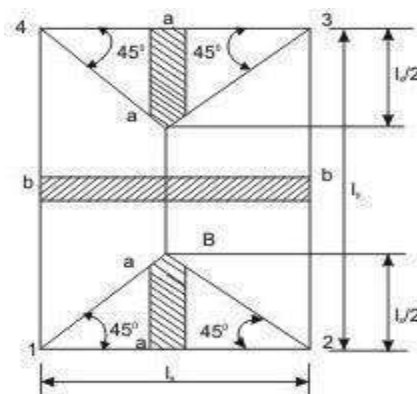

Figure 2.2 strips for shear

## Computation of shear force

Shear forces are computed following the procedure stated below with reference to Fig. 2.2.

The two-way slab of Fig. 2.2 is divided into two trapezoidal and two triangular zones by

drawing lines from each corner at an angle of  $45^\circ$ . The loads of triangular segment A will be transferred to beam 1-2 and the same of trapezoidal segment B will be beam 2-3. The shear forces per unit width of the strips aa and bb are highest at the ends of strips. Moreover, the length of half the strip bb is equal to the length of the strip aa. Thus, the shear forces in both strips are equal and we can write,

$$V_u = W_u (l/2)$$

where  $W_u$  = intensity of the uniformly distributed loads.

The nominal shear stress acting on the slab is then determined from

$$\tau_v = \frac{V_u}{bd}$$

### Computation of bending moments

Two-way slabs spanning in two directions at right angles and carrying uniformly distributed loads may be analysed using any acceptable theory. Pigeoud's or Westergaard's theories are the suggested elastic methods and Johansen's yield line theory is the most commonly used in the limit state of collapse method and suggested by IS 456 in the note of cl. 24.4. Alternatively, Annex D of IS 456 can be employed to determine the bending moments in the two directions for two types of slabs: (i) restrained slabs, and (ii) simply supported slabs. The two methods are explained below:

#### (i) Restrained slabs

Restrained slabs are those whose corners are prevented from lifting due to effects of torsional moments. These torsional moments, however, are not computed as the amounts of reinforcement are determined from the computed areas of steel due to positive bending moments depending upon the intensity of torsional moments of different corners. Thus, it is essential to determine the positive and negative bending moments in the two directions of restrained slabs depending on the various types of panels and the aspect ratio  $l_y/l_x$ .

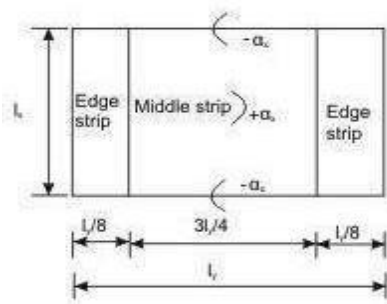

Figure 2.3(a): For Span  $l_x$

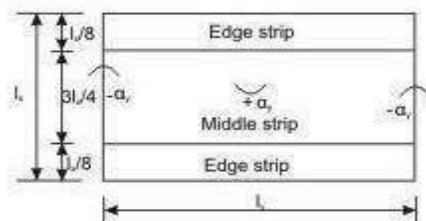

Figure 2.3(b): For Span  $l_y$

Restrained slabs are considered as divided into two types of strips in each direction: (i) one middle strip of width equal to three-quarters of the respective length of span in either direction, and (ii) two edge strips, each of width equal to one-eighth of the respective length of span in either direction. Figures 2.3 (a) and b present the two types of strips for spans  $l_x$  and  $l_y$  separately.

The maximum positive and negative moments per unit width in a slab are determined from

$$M_x = \alpha_x w l_x^2 \quad (1)$$

$$M_y = \alpha_y w l_y^2 \quad (2)$$

where  $\alpha_x$  and  $\alpha_y$  are coefficients given in Table 26 of IS 456, Annex D, cl. D-1.1. Total design load per unit area is  $w$  and lengths of shorter and longer spans are represented by  $l_x$  and  $l_y$ , respectively. The values of  $\alpha_x$  and  $\alpha_y$ , given in Table 26 of IS 456, are for nine types of panel having eight aspect ratios of  $l_x/l_y$  from one to two at an interval of 0.1. The above maximum bending moments are applicable only to the middle strips and no redistribution shall be made.

Tension reinforcing bars for the positive and negative maximum moments are to be provided in the respective middle strips in each direction. Figure 2.3 shows the positive and negative coefficients  $\alpha_x$  and  $\alpha_y$ .

The edge strips will have reinforcing bars parallel to that edge following the minimum amount as stipulated in IS 456.

### (ii) Simply supported slabs

The maximum moments per unit width of simply supported slabs, not having adequate provision to resist torsion at corners and to prevent the corners from lifting, are determined from Eqs. (1) and (2), where  $\alpha_x$  and

$\alpha_y$  are the respective coefficients of moments as given in

Table 27 of IS 456, cl. D-2. The notations  $M_x$ ,  $M_y$ ,  $w$ ,  $l_x$  and  $l_y$  are the same as mentioned

below Eqs. (1) and (2) in (i) above.

### Detailing of Reinforcement

The detailings of reinforcing bars for (i) restrained slabs and (ii) simply supported slabs are discussed separately for the bars either for the maximum positive or negative bending moments or to satisfy the requirement of minimum amount of steel.

#### (i) Restrained slabs

The maximum positive and negative moments per unit width of the slab calculated by employing Eqs. (1) and (2) are applicable only to the respective middle strips (Fig. 2.3). There shall be no redistribution of these moments. The reinforcing bars so calculated from the maximum moments are to be placed satisfying the following stipulations of IS 456.

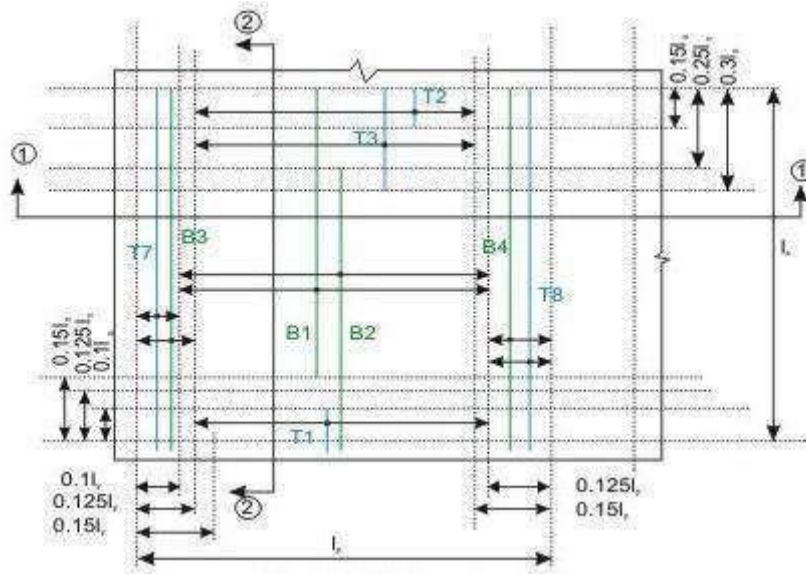

Figure 2.4(a) Bars along  $l_x$  only

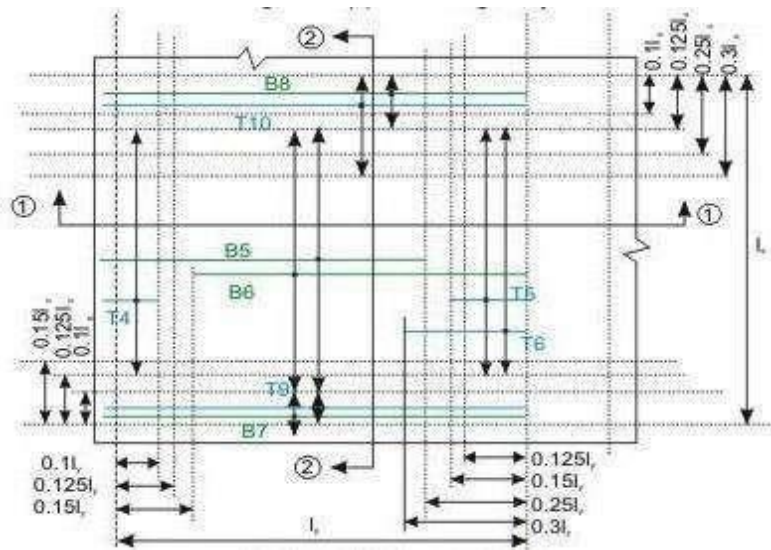

Figure 2.4(b) Bars along  $l_y$  only

Figure 2.4 Reinforcement of two-way slab (except torsion reinforcement)

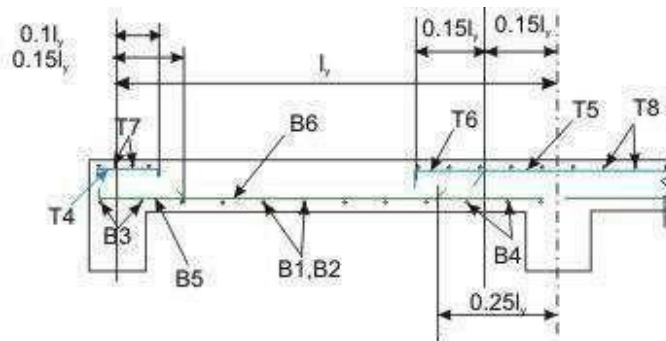

Figure 2.4(c)

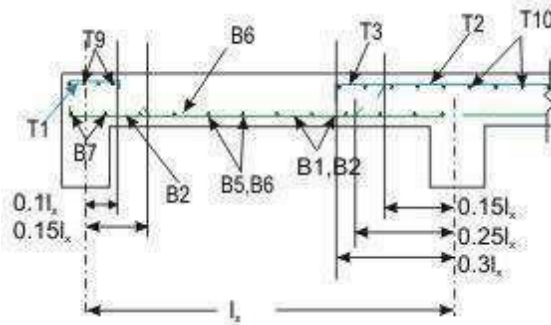

Figure 2.4(d)

Figure 2.4 Reinforcement of two-way slab (except torsion reinforcement)

- Bottom tension reinforcement bars of mid-span in the middle strip shall extend in the lower part of the slab to within  $0.25l_x$  of a continuous edge, or  $0.15l_x$  of a discontinuous edge (cl. D-1.4 of IS 456). Bars marked as B1, B2, B5 and B6 in Figs. 2.4 a and b are these bars.
- Top tension reinforcement bars over the continuous edges of middle strip shall extend in the upper part of the slab for a distance of  $0.15l_x$  from the support, and at least fifty per cent of these bars shall extend a distance of  $0.3l_x$  (cl. D-1.5 of IS 456). Bars marked as T2, T3, T5 and T6 in Figs. 2.4 a and b are these bars.
- To resist the negative moment at a discontinuous edge depending on the degree of fixity at the edge of the slab, top tension reinforcement bars equal to fifty per cent of that provided at mid-span shall extend  $0.1l_x$  into the span (cl. D-1.6 of IS 456). Bars marked as T1 and T4 in Figs. 2.4 a and b are these bars.
- The edge strip of each panel shall have reinforcing bars parallel to that edge satisfying the requirement of minimum reinforcement. The bottom and top bars of the edge strips are explained below.
- Bottom bars B3 and B4 (Fig. 2.4 a) are parallel to the edge along  $l_x$  for the edge strip for span  $l_y$ , satisfying the requirement of minimum amount of steel (cl. D-1.7 of IS 456).

- Bottom bars B7 and B8 (Fig. 2.4 b) are parallel to the edge along  $l_y$  for the edge strip for span  $l_x$ , satisfying the requirement of minimum amount of steel (cl. D-1.7 of IS 456).
- Top bars T7 and T8 (Fig. 2.4a) are parallel to the edge along  $l_x$  for the edge strip for span  $l_y$ , satisfying the requirement of minimum amount of steel (cl. D-1.7 of IS 456).
- Top bars T9 and T10 (Fig. 2.4b) are parallel to the edge along  $l_y$  for the edge strip for span  $l_x$ , satisfying the requirement of minimum amount of steel (cl. D-1.7 of IS 456).

**(ii) Simply supported slabs**

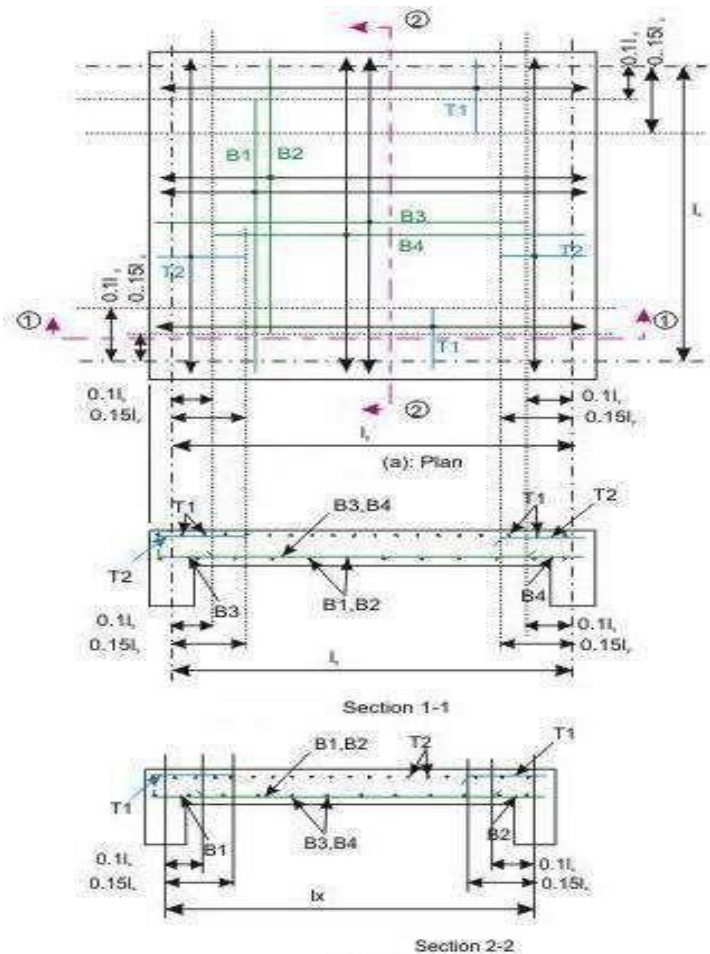

Figure 2.5 Simply supported two-way slab, corners not held down

Figures 2.5 a, b and c present the detailing of reinforcing bars of simply supported slabs not having adequate provision to resist torsion at corners and to prevent corners from lifting. Clause D-2.1 stipulates that fifty percent of the tension reinforcement provided at mid-span should extend to the supports. The remaining fifty per cent should extend to within  $0.1l$  or  $0.1$  of the support, as appropriate.

### Numerical Problem

Design a R.C. slab for a room measuring  $5\text{m} \times 6\text{m}$  size. The slab is simply supported on all the four edges, with corners held down and carries a super-imposed load of  $3\text{ KN/m}^2$  inclusive of floor finish etc. Use M20 grade of concrete and Fe 415 grade of steel.

Solution

Computation of loading and bending moment

From deflection point of view  $l/d=20$  for simply supported slab. Let us assume  $p_t = 0.2\%$  for an under-reinforced section. Hence from figure 4 of IS 456:2000, we get modification factor = 1.68.

$$\text{Hence } l/d = 20 \times 1.68 = 33.6$$

$$\text{and } d = l/33.6 =$$

$$5000/33.6 = 148.8 \text{ mm} \text{ Providing } 20 \text{ mm nominal}$$

$$\text{over and } 8 \text{ mm bar } D = 148.8 + 20 + 8 = 172.8 \text{ mm}$$

Hence assume an overall depth of 180 mm for the purpose of computing dead load

$$(i) \text{ Self weight of slab per } m^2 = 0.18 \times 1 \times 1 \times 25 = 4.5 \text{ KN/m}^2$$

$$(ii) \text{ Super-imposed load @ } 3 \text{ KN/m}^2 = 3$$

$$\text{KN/m}^2 \text{ Total load } w = 7.5 \text{ KN/m}^2$$

$$\text{Hence } w_u = 1.5 \times 7.5 = 11.25$$

$$\text{KN/m}^2 \text{ Taking an effective depth of } 150$$

$$\text{mm. Effectively } l_y = 6 + 0.15 = 6.15 \text{ m Effect}$$

$$\text{ively } l_x = 5 + 0.15 = 5.15 \text{ m}$$

$$\text{Therefore } \frac{l_y}{l_x} = \frac{6.15}{5.15} = 1.2 < 2$$

From table 27 of IS 456:2000  $\alpha_x = 0.072$  and  $\alpha_y = 0.056$

$$M_{ux} = \alpha_x w_u l_x^2 = 0.072 \times 11.25 \times 5.15^2 = 21.483 \text{ KN-m}$$

$$M_{uy} = \alpha_y w_u l_y^2 = 0.056 \times 11.25 \times 6.15^2 = 16.709 \text{ KN-m}$$

$$\text{For short span, width of middle strip} = \frac{3}{4} l_y = \frac{3}{4} \times 6.15 = 4.61 \text{ m}$$

$$\text{Width of edge strip} = 0.5 \times (6.15 - 4.61) = 0.77 \text{ m}$$

$$\text{For long span, width of middle strip} = \frac{3}{4} l_x = \frac{3}{4} \times 5.15 = 3.87 \text{ m}$$

$$\text{Width of edge strip} = 0.5 \times (5.15 - 3.87) =$$

$$0.64 \text{ m} \text{ Computation of effective depth and total de}$$

pth

$$d = \sqrt{\frac{M_{ux}}{R_{ub}}} = \sqrt{\frac{21.483 \times 10^6}{2.761 \times 10^3}} = 88.2 \text{ mm}$$

However, from the requirement of deflection keep  $D = 180 \text{ mm}$ .

Therefore,  $d = 180 - 20 - 4 = 156 \text{ mm}$  and that for long span  $d = 156 - 8 = 148$

mm Computation of steel reinforcement for short span

$$A_{st} = 0.5 f_{ck} \left[ 1 - \sqrt{1 - \frac{4.6 M_{ux}}{f_{ck} b d^2}} \right] b d = 403.2 \text{ mm}^2$$

$$\text{Spacing of 8mm bar } S_x = \frac{1000 \times 50.3}{403.2} = 124.7 \text{ mm}$$

However, use 8mm bars @ 120mm/c for the middle strip of width 4.61m. Edge

strip of length = 0.77m

$$\text{Thereinforcement in the edge strip} = \frac{0.12 \times 180 \times 1000}{100} = 216 \text{ mm}^2$$

Provides spacing 8mm 225c/c.

Computation of steel reinforcement for long span

$$A_{st} = 327.9 \text{ mm}^2$$

Spacing of 8mm bar  $S_y = 153.4 \text{ mm}$

Provide 8mm bars

@ 150mm/c for the middle strip of width 3.87m. Fore edge strip of width =

0.64m,  $A_{st} = 216 \text{ mm}^2$

Hence provides spacing 8mm @ 225 c/c.

Torsional reinforcement at corners

$$\text{Size of torsion mesh} = \frac{l_x}{5} = \frac{5.15}{5} = 1.03 \text{ m} \quad \text{from the centre of support } 1.03 + 0.08 = 1.105$$

from the edge of the slab.

$$\text{Area of torsional reinforcement} = \frac{3}{4} A_{st} = \frac{3}{4} \times 403.2 = 302.4 \text{ mm}^2$$

Required spacing 8mm @ 166mm



beams having steel reinforcement both on tensile and compressive faces are known as doubly reinforced beams.

Doubly reinforced beams, therefore, have moment of resistance more than the singly reinforced beams of the same depth for particular grades of steel and concrete. In many practical situations, architectural or functional requirements may restrict the overall depth of the beams. However, other than in doubly reinforced beams compression steel reinforcement is provided when:

- (i) Some sections of a continuous beam with moving loads undergo change of sign of the bending moment which makes compression zone as tension zone or vice versa.
- (ii) The ductility requirement has to be followed.
- (iii) The reduction of long term deflection is needed.

### Basic Principle

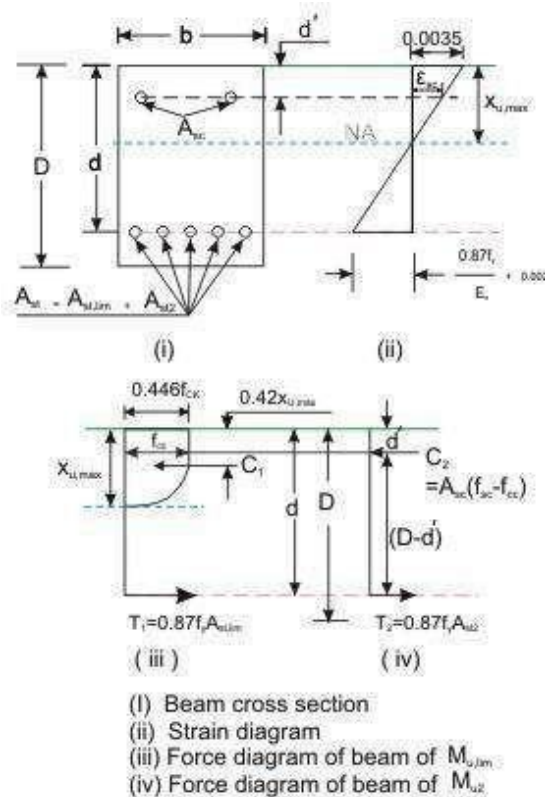

Figure 2.7 Stress, strain and force diagrams of doubly reinforced beam

The moment of resistance  $M_u$  of the doubly reinforced beam consists of (i)  $M_{u,lim}$  of singly reinforced beam and (ii)  $M_{u2}$  because of equal and opposite compression and tension forces ( $C_2$  and  $T_2$ ) due to additional steel reinforcement on compression and tension faces of the beam (Figs. 2.6 and 7). Thus, the moment of resistance  $M_u$  of a doubly reinforced beam is

$$M_u = M_{u,lim} + M_{u2} \quad (3)$$

$$= 0.36 x_{u,max} \left( 1 - 0.42 \frac{x_{u,max}}{d} \right) f_b d^2 \quad (4)$$

$$M_{u,lim} = \frac{1}{d} \left( 1 - \frac{x_{u,max}}{d} \right) c k$$

Also,  $M_{u,lim}$  can be written

$$M_{u,lim} = 0.87 A_{st,lim} f_y (d - 0.416 x_{u,max}) \quad (5)$$

The additional moment  $M_{u2}$  can be expressed in two ways (Fig. 2.7): considering (i) the compressive force  $C_2$  due to compression steel and (ii) the tensile force  $T_2$  due to additional steel on tension face. In both the equations, the lever arm is  $(d - d')$ . Thus, we have

$$M_{u2} = A_{sc} (f_{sc} - f_{cc}) (d - d') \quad (6)$$

$$M_{u2} = A_{st2} (0.87 f_y) (d - d') \quad (7)$$

where  $A_{sc}$  = area of compression steel reinforcement

$f_{sc}$  = stress in compression steel reinforcement

$f_{cc}$  = compressive stress in concrete at the level of centroid of compression steel reinforcement

$A_{st2}$  = area of additional steel reinforcement

Since the additional compressive force  $C_2$  is equal to the additional tensile force  $T_2$ , we have

$$A_{sc} (f_{sc} - f_{cc}) = A_{st2} (0.87 f_y) \quad (8)$$

Any two of the three equations (Eqs. 6-8) can be employed to determine  $A_{sc}$  and  $A_{st2}$ .

The total tensile reinforcement  $A_{st}$  is then obtained from:

$$A_{st} = A_{st1} + A_{st2} \quad (9)$$

$$A_{st1} = \frac{p}{1000} \frac{b d}{f_y} \frac{M_{u,lim}}{(d - 0.42 x_{u,max})} \quad (10)$$

### Determination of $f_{sc}$ and $f_{cc}$

It is seen that the values of  $f_{sc}$  and  $f_{cc}$  should be known before calculating  $A_{sc}$ . The following procedure may be followed to determine the value of  $f_{sc}$  and  $f_{cc}$  for the design type of problems (and not for analysing a given section). For the design problem the depth of the

neutral axis may be taken as  $x_{u,max}$  as shown in Fig. 2.7. From Fig. 2.7, the strain at the level of compression steel reinforcement  $\epsilon_{sc}$  may be written as

$$\epsilon_{sc} = 0.0035 \left( 1 - \frac{d}{x_{u,max}} \right) \quad (11)$$

### $f_{sc}$ for Cold worked bars Fe415 and Fe500

Table 2.1 Values of  $f_{sc}$  and  $\epsilon_{sc}$

Stress level	Fe415		Fe500	
	Strain $\epsilon_{sc}$	Stress $f_{sc}$ (N/mm <sup>2</sup> )	Strain $\epsilon_{sc}$	Stress $f_{sc}$ (N/mm <sup>2</sup> )
$0.80f_{yd}$	0.00144	288.7	0.00174	347.8
$0.85f_{yd}$	0.00163	306.7	0.00195	369.6
$0.90f_{yd}$	0.00192	324.8	0.00226	391.3
$0.95f_{yd}$	0.00241	342.8	0.00277	413.0
$0.975f_{yd}$	0.00276	351.8	0.00312	423.9
$1.0f_{yd}$	0.00380	360.9	0.00417	434.8

### Design type of problems

In the design type of problems, the given data are  $b, d, D$ , grades of concrete and steel. The designer has to determine  $A_{sc}$  and  $A_{st}$  of the beam from the given factored moment.

**Step 1:** To determine  $M_{u,lim}$  and  $A_{st,lim}$  from Eqs. 4 and 10, respectively.

**Step 2:** To determine  $M_{u2}$ ,  $A_{sc}$ ,  $A_{st2}$  and  $A_{st}$  from Eqs. 3, 5, 8 and 9, respectively.

**Step 3:** To select the number and diameter of bars from known values of  $A_{sc}$  and  $A_{st}$ .

### Analysis type of problems

In the analysis type of problems, the data given are  $b, d, d', D, f_c, f_s, A_{ck}$  and  $A_{st}$ . It is required to determine the moment of resistance  $M_u$  of such beams.

**Step 1:** To check if the beam is under-reinforced or over-reinforced.

First,  $x_{u,max}$  is determined assuming it has reached limiting stage using  $\frac{x_{u,max}}{d}$  coefficients as given in cl. 38.1, Note of IS 456. The strain of tensile steel  $\epsilon_{st}$  is computed from

$$\epsilon_{st} = \frac{\epsilon_c(d - x_{u,max})}{x_{u,max}} \text{ and is checked if } \epsilon_{st} \text{ has reached the yield strain of steel:}$$

$$\epsilon_{st,yield} = \frac{f_y}{1.15E} + 0.002$$

The beam is under-reinforced or over-reinforced if  $\epsilon_{st}$  is less than or more than the yield strain.

**Step 2:** To determine  $M_{u,lim}$  from Eq. 4 and  $A_{st,lim}$  from the  $p_{t,lim}$ .

**Step 3:** To determine  $A_{st2}$  and  $A_{sc}$  from Eqs. 9 and 8, respectively.

**Step 4:** To determine  $M_{u2}$  and  $M_u$  from Eqs. 6 and 3, respectively.

### Numerical Problem

Determine the moment of resistance of an existing beam having the following data:

$b=350\text{mm}; d=900\text{mm}; d'=50\text{mm}$ . Tension reinforcement: 5-

20mm HYSD bars (Fe 415); compression reinforcement 2-20mm HYSD bars

(Fe

415); grade of concrete M15.

### Solution

$$A_{st} = 5x \frac{\pi}{4} (20)^2 = 1570.8 \text{ mm}^2; 4$$

$$A_{sc} = 2x \frac{\pi}{4} (20)^2 = 628.3 \text{ mm}^2$$

$$T = 0.87 f_y A_{st} = 0.87 \times 415 \times 1570.8 = 567120 \text{ N}$$

$$C_u = 0.36 f_{ck} x_u b + f_{sc} A_{sc} - 0.446 f_{ck} A_{sc}$$

$$= 1890 x_u + 628.3 f_{sc} - 4203$$

$$\text{Let assume } x_u = 230 \text{ mm; hence } x_u = 98.6 \text{ mm} > d'$$

$$\epsilon_{sc} = \frac{0.0035(x_u - d)}{x_u} = \frac{0.0035(230 - 50)}{230} = 0.00274$$

Hence from stress-strain curve, we get  $f_{sc} = 351 \text{ N/mm}^2$

$$C_u = 1890 \times 230 + (628.3 \times 351) - 4203 = 651030 \text{ N}$$

This is much more than  $T_u = 567120 \text{ N}$ . Hence take  $x_u = 190 \text{ mm}$ .

$$\varepsilon_{sc} = \frac{0.0035(x_u - d)}{x_u} = \frac{0.0035(190 - 50)}{190} = 0.00258$$

Hence  $f_{sc} = 347 \text{ N/mm}^2$

$$C_u = 572919 \text{ N} \approx T$$

Therefore,  $M_u = 1890 \times 190 \times (900 - 0.416 \times 190) + (628.3 \times 347 - 4203) \times (900 - 50)$

476.5 kN-m

## T-beams and L-beams

Beams having effectively *T-sections* and *L-sections* (called *T-beams* and *L-beams*) are commonly encountered in beam-supported slab floor systems [Figs. 2.8]. In such situations, a portion of the slab acts integrally with the beam and bends in the longitudinal direction of the beam. This slab portion is called the *flange* of the T- or L-beam. The beam portion below the flange is often termed the *web*, although, technically, the web is the full rectangular portion of the beam other than the overhanging parts of the flange. Indeed, in shear calculations, the web is interpreted in this manner.

When the flange is relatively wide, the flexural compressive stress is not uniform over its width. The stress varies from a maximum in the web region to progressively lower values at points farther away from the web. In order to operate within the framework of the theory of flexure, which assumes a *uniform* stress distribution across the *width* of the section, it is necessary to define an *effective flange*.

The 'effective width of flange' may be defined as the width of a hypothetical flange that resists in-plane compressive stresses of uniform magnitude equal to the peak stress in the original wide flange, such that the value of the resultant longitudinal compressive force is the same (Fig. 2.8).

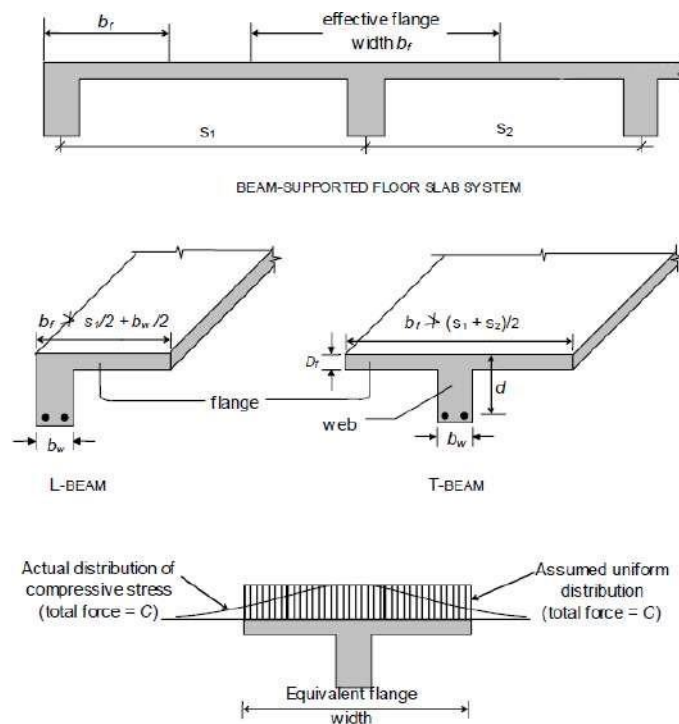

Figure 2.8 T-beams and L-beams in beam-supported floor slab systems

The effective flange width is found to increase with increased span, increased web width and increased flange thickness. It also depends on the type of loading (concentrated, distributed, etc.) and the support conditions (simply supported, continuous, etc.). Approximate formulae

for estimating the effective width of flange ' $b_f$ ' (Cl.23.1.2 of Code) are given as follows:

$$b_f = \begin{cases} l_0/6 + b_w + 6D_f & \text{for T-Beam} \\ l_0/12 + b_w + 3D_f & \text{for L-Beam} \end{cases} \quad (12)$$

where  $b_w$  is the breadth of the web,  $D_f$  is the thickness of the flange [Fig.2.8], and  $l_0$  is the distance between points of zero moment in the beam (which may be assumed as 0.7 times the effective span in continuous beams and frames). Obviously,  $b_f$  cannot extend beyond the slab portion tributary to a beam, i.e., the actual width of slab available. Hence, the calculated  $b_f$  should be restricted to a value that does not exceed  $(s_1 + s_2)/2$  in the case of T-beams, and  $s_1/2 + b_w/2$  in the case of L-beams, where the spans  $s_1$  and  $s_2$  of the slab are as marked in Fig. 2.8.

In some situations, *isolated* T-beams and L-beams are encountered, i.e., the slab is discontinuous at the sides, as in a footbridge or a 'stringer beam' of a staircase. In such cases, the Code [Cl.23.1.2(c)] recommends the use of the following formula to estimate the effective width of flange ' $b_f$ ':

$$b_f = \begin{cases} \left[ \frac{l_0}{t_0/b + 4} + b_w \right] & \text{for isolated T-Beams} \\ \left[ \frac{0.5l_0}{l_0/b + 4} + b_w \right] & \text{for isolated L-Beam} \end{cases} \quad (13)$$

where  $b$  denotes the actual width of flange; evidently, the calculated value of  $b_f$  should not exceed  $b$ .

### Analysis of Singly Reinforced Flanged Sections

The procedure for analysing flanged beams at ultimate loads depends on whether the neutral axis is located in the flange region [Fig.2.8(a)] or in the web region [Fig.2.8(b)].

If the neutral axis lies within the flange (i.e.,  $x_u \leq D_f$ ), then as in the analysis at service loads all the concrete on the tension side of the neutral axis is assumed ineffective, and the T-section may be analysed as a rectangular section of width  $b_f$  and effective depth  $d$  [Fig.2.8(a)]. Accordingly, Eq.(7) and Eq.(9) are applicable with  $b$  replaced by  $b_f$ .

If the neutral axis lies in the web region (i.e.,  $x_u > D_r$ ), then the compressive stress is carried by the concrete in the flange and a portion of the web, as shown in Fig. 2.8(b). It is convenient to consider the contribution to the resultant compressive force  $C$ , from the web portion ( $b \times x$ ) and the flange portion (width  $b - b_f$ ) separately, and to sum up these effects. Estimating the compressive force  $C$  in the web and its moment contribution  $M$  is easy, as the full stress block is operative:

$$C_{uw} = 0.361 f_{ck} b_w x_u \quad (14)$$

$$M_{uw} = C_{uw} (d - 0.416 x_u) \quad (15)$$

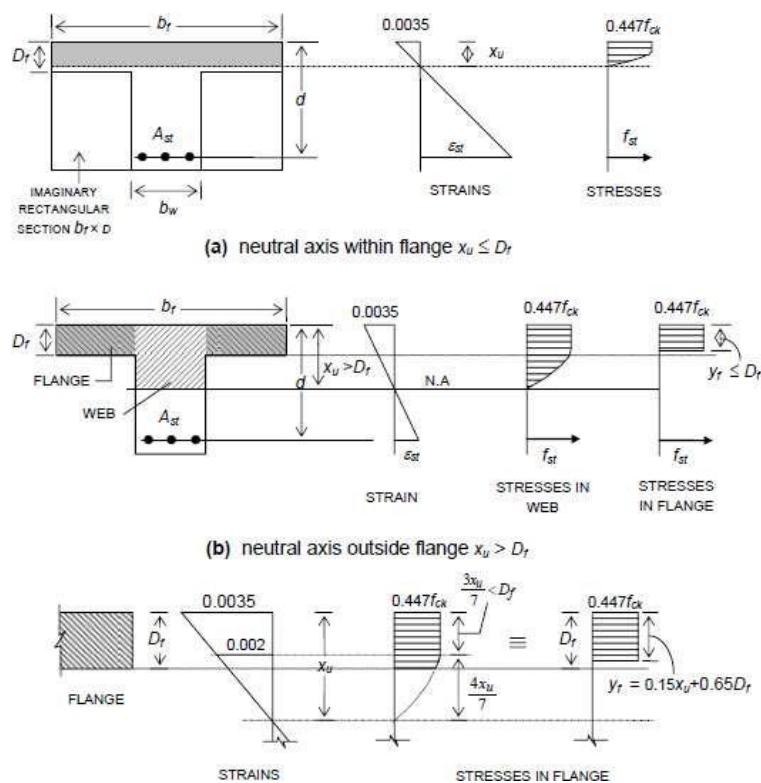

Figure 2.9 Behaviour of flanged beam section at ultimate limit state

However, estimating the compressive force  $C_{uf}$  in the flange is rendered difficult by the fact that the stress block for the flange portions may comprise a rectangular area plus a truncated parabolic area [Fig. 2.8(b)]. A general expression for the total area of the stress block operative in the flange, as well as an expression for the centroidal location of the stress block, is evidently not convenient to derive for such a case. However, when the stress block over the flange depth contains only a rectangular area (having a uniform stress  $0.447 f_{ck}$ ), which

occurs when  $\frac{x_u^3}{7u} \geq D$ , an expression for  $C$  and its moment contribution  $M_{uf}$  can easily be

formulated. For the case,  $1 < x_u/D_f < 7/3$ , an equivalent rectangular

stress block (of area  $0.447f_y$ ) can be conceived, for convenience, with

an equivalent depth  $y_f \leq D$ , as shown in

Fig. 2.8(c). The expression for  $y_f$  given in the Code (Cl. G-2.2.1) is necessarily an

approximation, because it cannot satisfy the 'two conditions of equivalence', in terms of

area of stress block as well as centroidal allocation. A general expression for  $y_f$  may be specified for

any  $x > D$ :

$$y_f = \begin{cases} 0.15x_u + 0.65D_f & \text{for } 1 < x_u/D_f < 7/3 \\ D_f & \text{for } D_f \geq 7/3 \end{cases} \quad (16)$$

The expressions for  $C$  and  $M$  are accordingly obtained as:

$$C_{uf} = 0.447f_{ck}(b_f - b_w)y_f \quad \text{for } x_u > D_f \quad (17)$$

$$M_{uf} = C_{uf}(d - y_f / 2) \quad (17a)$$

The location of the neutral axis is fixed by the force equilibrium condition (with  $y_f$  expressed in terms of  $x_u$  [Eq. 17]).

$$C_{uf} + C_{uf} = f_{st}A_{st} \quad (18)$$

where  $f_{st} = 0.87f_y$  for  $x_u \leq x_{u,max}$ . Where  $x_u > x_{u,max}$ , the strain compatibility method has to be employed to determine  $x_u$ .

Substituting Eq. 14 and Eq. 17 in Eq. 18, and solving for  $x_u$ ,

$$x_u = \frac{f_{st}A_{st} - 0.447f_{ck}(b_f - b_w)y_f}{0.361f_{ck}b_w} \quad \text{for } x_u > D \quad (19)$$

The final expression for the ultimate moment of resistance  $M_{uR}$  is obtained as:

$$M_{uR} = M_{uw} + M_{uf} \quad (20)$$

$$\Rightarrow M_{uR} = 0.361f_{ck}b_w x_u (d - 0.416x_u) + 0.447f_{ck}(b_f - b_w)y_f (d - y_f/2) \quad (21)$$

## Limiting Moment of Resistance

The limiting moment of resistance  $M_{u,lim}$  is obtained for the condition  $x = x_{u,max}$ , where  $x_{u,max}$  takes the values of  $0.531d$ ,  $0.479d$  and  $0.456d$  for Fe 250, Fe 415 and Fe 500 grades of tensile steel reinforcement. The condition  $x/D \geq 7/3$  in Eq. 4.69, for the typical case of Fe 415,

works out, for  $x = x_{u,max}$ , as  $0.479d/D_f \geq 7/3$ , i.e.,  $D/d_f \leq 0.205$ . The Code (Cl. G-2.2)

suggests as a simplified condition of  $d/D_f \leq 0.2$  for all grades of steel — to represent the condition  $x/D \geq 7/3$ .

Eq.(21) and Eq.(16) take the following forms:

$$M_{u,lim} = 0.361 f_{ck} b_w x_{u,max} (d - 0.416 x_{u,max}) + 0.447 f_{ck} (b - b_w) y_f (d - y_f / 2) \text{ for } x_{u,max} > D_f \quad (22)$$

$$y_f = \begin{cases} 0.15 x_{u,max} + 0.65 D_f & \text{for } D_f/d > 0.2 \\ D_f & \text{for } D_f/d \leq 0.2 \end{cases} \quad (23)$$

The advantage of using Eq.(23) in lieu of the more exact Eq.(16) (with  $x = x_{u,max}$ ) is that the estimation of  $y_f$  is made somewhat simpler. Of course, for  $x_{u,max} \leq D_f$  (i.e., neutral axis within the flange),

$$M_{u,lim} = 0.361 f_{ck} b_f x_{u,max} (d - 0.416 x_{u,max}) \text{ for } x_{u,max} \leq D_f \quad (24)$$

As mentioned earlier, when it is found by analysis of a given T-section that  $x > x_{u,max}$ , then the strain compatibility method has to be applied. As an approximate and conservative estimate,  $M_{uR}$  may be taken as  $M_{u,lim}$ , given by Eq.(23)/(24). From the point of view of design (to be discussed in Chapter 5),  $M_{u,lim}$  provides a measure of the ultimate moment

capacity that can be expected from a T-section of given proportions. If the section has to be designed for a factored moment  $M_u > M_{u,lim}$ , then this calls for the provision of compression reinforcement in addition to extra tension reinforcement.

## Design Procedure

In the case of a *continuous* flanged beam, the negative moment at the face of the support generally exceeds the maximum positive moment (at or near the midspan), and hence governs the proportioning of the beam cross-section. In such cases of negative moment, if the slab is

located on top of the beam (as is usually the case), the flange is under flexural tension and hence the concrete in the flange is rendered ineffective. The beam section at the support is therefore to be designed as a rectangular section for the factored negative moment. Towards the midspan of the beam, however, the beam behaves as a proper flanged beam (with the flange under flexural compression). As the width of the web  $b$  and the overall depth  $D$  are already fixed from design considerations at the support, all that remains to be determined is the area of reinforcing steel; the *effective width of flange* is determined as suggested by the Code.

The determination of the actual reinforcement in a flanged beam depends on the location of the neutral axis  $x$ , which, of course, should be limited to  $x_u$ . If  $M_u$  exceeds  $M_{u,lim}$  for a singly reinforced flange section, the depth of these sections should be suitably increased; otherwise, a doubly reinforced section is to be designed.

#### Neutral Axis within Flange ( $x_u \leq D_f$ ):

This is, by far, the most common situation encountered in building design. Because of the very large compressive concrete area contributed by the flange in T-beam and L-beams of usual proportions, the neutral axis lies within the flange ( $x_u \leq D_f$ ), whereby the section behaves like a rectangular section having width  $b$  and effective depth  $d$ .

A simple way of first checking  $x_u \leq D_f$  is by verifying  $M_u \leq (M_{uR})_{x_u = D_f}$  where  $(M_{uR})_{x_u = D_f}$

is the limiting ultimate moment of resistance for the condition  $x_u = D_f$  and is given by

$$(M_{uR})_{x_u = D_f} = 0.361 f_{ck} b_f D_f (d - 0.416 D_f) \quad (25)$$

It may be noted that the above equation is meaningful only if  $x_{u,max} > D_f$ . In rare situations involving very thick flanges and relatively shallow beams,  $x_{u,max}$  may be less than  $D_f$ . In such cases,  $M_{u,lim}$  is obtained by substituting  $x_{u,max}$  in place of  $D_f$  in Eq. (25).

#### Neutral Axis within Web ( $x_u > D_f$ ):

When  $M_u > (M_{uR})_{x_u = D_f}$ , it follows that  $x_u > D_f$ . The accurate determination of  $x_u$  can be laborious. The contributions of the compressive forces  $C_{uw}$  and  $C_{uf}$  in the 'web' and 'flange' may be accounted for separately as follows:

$$M_{uR} = C_{uw}(d - 0.416 x_u) + C_{uf}(d - y_f/2) \quad (26)$$

$$C_{uw} = 0.361 f_{ck} b_w x_u \quad (27)$$

$$C_{uf} = 0.447 f_{ck} (b_f - b_w) y_f \quad (28)$$

and the equivalent flange thickness  $y_f$  is equal to or less than  $D_f$  depending

on whether  $x_u$  exceeds  $7D_f/3$  or not.

For  $x_{u,max} \geq 7D_f/3$ , the value of the ultimate moment of resistance  $(M_{uR})_{x=7D_f/3}$

corresponding to  $x_u = 7D_f/3$  and  $y_f = D_f$  may be first computed. If the factored moment

$M_u \geq (M_{uR})_{x=7D_f/3}$ , it follows that  $x_u > 7D_f/3$  and  $y_f = D_f$ . Otherwise,

$$D_f < x_u < 7D_f/3 \text{ for } (M_{uR})_{x=D_f} < M_u < (M_{uR})_{x=7D_f/3} \text{ and } y_f = 0.15x_u + 0.65D_f \quad (29)$$

Inserting the appropriate value—  $D_f$  for the expression for  $y_f$  in Eq. (29), in Eq. (26), the

resulting quadratic equation (in terms of the unknown  $x_u$ ) can be solved to yield the

correct value of  $x_u$ . Corresponding to this value of  $x_u$ , the values of  $C_{uw}$  and  $C_{uf}$  can be computed [Eq.

(27), (28)] and the required  $A_{st}$  obtained by solving the force equilibrium equation.

$$T_u = 0.87 f_y A_{st} = C_{uw} + C_{uf}$$

$$\Rightarrow (A)_{required} = \frac{C_{uw} + C_{uf}}{0.87 f_y} \quad (30)$$

### Numerical Problem

A continuous T-beam has the cross-sectional dimensions shown in figure below. The web dimensions have been determined from the consideration of negative moment at support and shear strength requirements. The span is 10 m and the design moment at midspan under factored loads is 800 kNm. Determine the flexural reinforcement requirement at midspan. Consider Fe415 steel. Assume that the beam is subjected to moderate exposure conditions.

Solution

#### Determining approximate $A_{st}$

Effective flange width  $b_f$

Actual flange width provided = 1500 mm;  $D_f = 100$  mm;  $b_w = 300$  mm

Maximum width permitted =  $(0.7 \times 10000) / 6 + 300 + (6 \times 100) = 2067$

mm > 1500 mm Therefore,  $b_f = 1500$  mm

Assuming  $d = 650$  mm and a lever arm  $z$  equal to larger of  $0.9d = 585$  mm

And  $D_f/2 = 600$  mm i.e.  $z = 600$  mm

$$(A_{st})_{required} = \frac{800 \times 10^6}{0.87 \times 415 \times 600} = 3693 \text{ mm}^2$$

- Providing 4 bars,  $\phi_{reqd} = \sqrt{\frac{3693/4}{\pi/4}} = 34.3 \text{ mm}$ , i.e., 36 mm

As 4-36 $\phi$  bars cannot be accommodated in one layer within the width  $b_w = 300$  mm, two layers are required.

Assuming a reduced  $d \approx 625$  mm,  $z \approx 625 - 100/2 = 575$  mm.

$$\Rightarrow (A_{st})_{reqd} \approx 3693 \times \frac{600}{575} = 3854 \text{ mm}^2.$$

- Provide 5-32 $\phi$  [ $A_{st} = 804 \times 5 = 4020 \text{ mm}^2$ ] with 3 bars in the lower layer plus 2 bars in the upper layer, with a clear vertical separation of 32 mm — as shown in Fig. 5.11(b). Assuming 8 mm stirrups and a clear 32 mm cover to stirrups,

$$\begin{aligned} \Rightarrow d &= 700 - 32 - 8 - \frac{1}{5} [(3 \times 16) + 2 \times (32 + 32 + 16)] \\ &= 700 - 40 - 41.6 = 618 \text{ mm} \end{aligned}$$

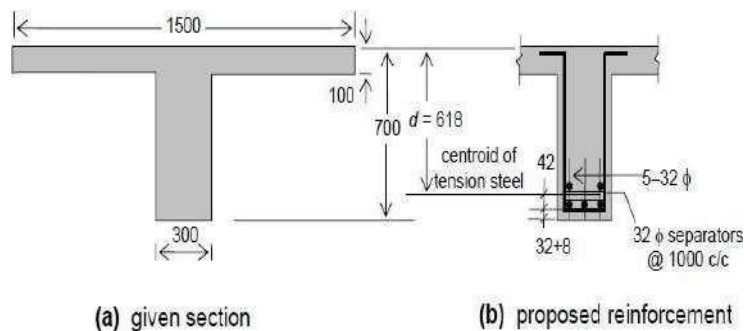

Figure: Reinforcement of T-beam of Example Problem

### Determining actual $A_{st}$

$$x_{u,max} = 0.479 \times 618 = 296 \text{ mm}$$

As  $x_{u,max} > D_f = 100 \text{ mm}$ , the condition  $x_u = D_f$  satisfies

$$x_u \leq x_{u,max}$$

- Assuming M25 concrete,  $f_{ck} = 25 \text{ MPa}$

$$\begin{aligned} (M_{uR})_{x_u=D_f} &= 0.362 \times 25 \times 1500 \times 100 \times (618 - 0.416 \times 100) \\ &= 782.5 \times 10^6 \text{ Nmm} < M_u = 800 \text{ kNm} \end{aligned}$$

$$\Rightarrow x > D \text{ and } M = C_u (d - 0.416x) + C_{uw} (d - y_f/2)$$

$$\text{where } C_{uw} = 0.362 f_{ck} b_w = 0.362 \times 25 \times 300 = (2715 x_u) \text{ N}$$

$$\text{and } C_{uf} = 0.447 f_{ck} (b - b_w) y_f = 0.447 \times 25 \times (1500 - 300) y_f = (13410 y_f) \text{ N}$$

Considering  $x_u = 7D_f/3 = 233 \text{ mm} (< x_{u,max} = 296 \text{ mm})$ ,  $y_f = D_f = 100 \text{ mm}$

$$\Rightarrow (M_{uR})_{x=7D/3} = (2715 \times 233)(618 - 0.416 \times 233) + (13410 \times 100)x(618 - 100/2)$$

$$= 1091.3 \times 10^6 \text{ Nmm} > M_u = 800 \text{ KNm}$$

Evidently,  $D < x < \frac{7}{3} D$ , for which  $y = 0.15x + 0.65D$

$$C = 13410(0.15x + 0.65 \times 100) = (2011.5x + 871650) \text{ N}$$

$$M = 800 \times 10^6 = (2715x)(618 - 0.416x) + (2011.5xu + 871650)x[618 - (0.15xu + 65)/2]$$

$$= -1280.3x^2 + 2790229.5x + 510.35 \times 10^6$$

Solving this quadratic equation,

$$x = 109.3 \text{ mm} < x_{u,max} = 296 \text{ mm}$$

$$\Rightarrow y = 0.15x + 65 = 81.4 \text{ mm}$$

$$\text{Applying } T = 0.87f_y A_{st} = C_{uw} + C_{uf}$$

$$(A)_{st,required} = \frac{(2715 \times 109.3) + (13410 \times 81.4)}{0.87 \times 415} = 3845 \text{ mm}^2$$

The reinforcement (5-32 $\Phi$ ;  $A_{st} = 4020 \text{ mm}^2$ , based on appropriate estimate of  $A_{st}$  [Fig.]) is evidently adequate and appropriate.

## Design of Staircase

The staircase is an important component of a building, and often the only means of access between the various floors in the building. It consists of a *flight* of steps, usually with one or more intermediate *landings* (horizontal slab platforms) provided between the floor levels. The horizontal top portion of a step (where the foot rests) is termed *tread* and the vertical projection of the step (i.e., the vertical distance between two neighbouring steps) is called *riser* [Fig. 2.10]. Values of 300 mm and 150 mm are ideally assigned to the tread and riser respectively — particularly in public buildings. However, lower values of tread (up to 250 mm) combined with higher values of riser (up to 190 mm) are resorted to in residential and factory buildings. The *width* of the stair is generally around 1.1 – 1.6 m, and in any case, should normally not be less than 850 mm; large stair widths are encountered in entrances to public buildings. The horizontal projection (plan) of an inclined flight of steps, between the first and last risers, is termed *going*. A typical flight of steps consists of two landings and one going, as depicted in Fig. 2.10(a). Generally, risers in a flight should not exceed about 12 in number. The steps in the flight can be designed in a number of ways: with *waist slab*, with *tread-riser* arrangement (without waist slab) or with *isolated tread slabs* — as shown in Fig. 2.10(b),(c),(d) respectively.

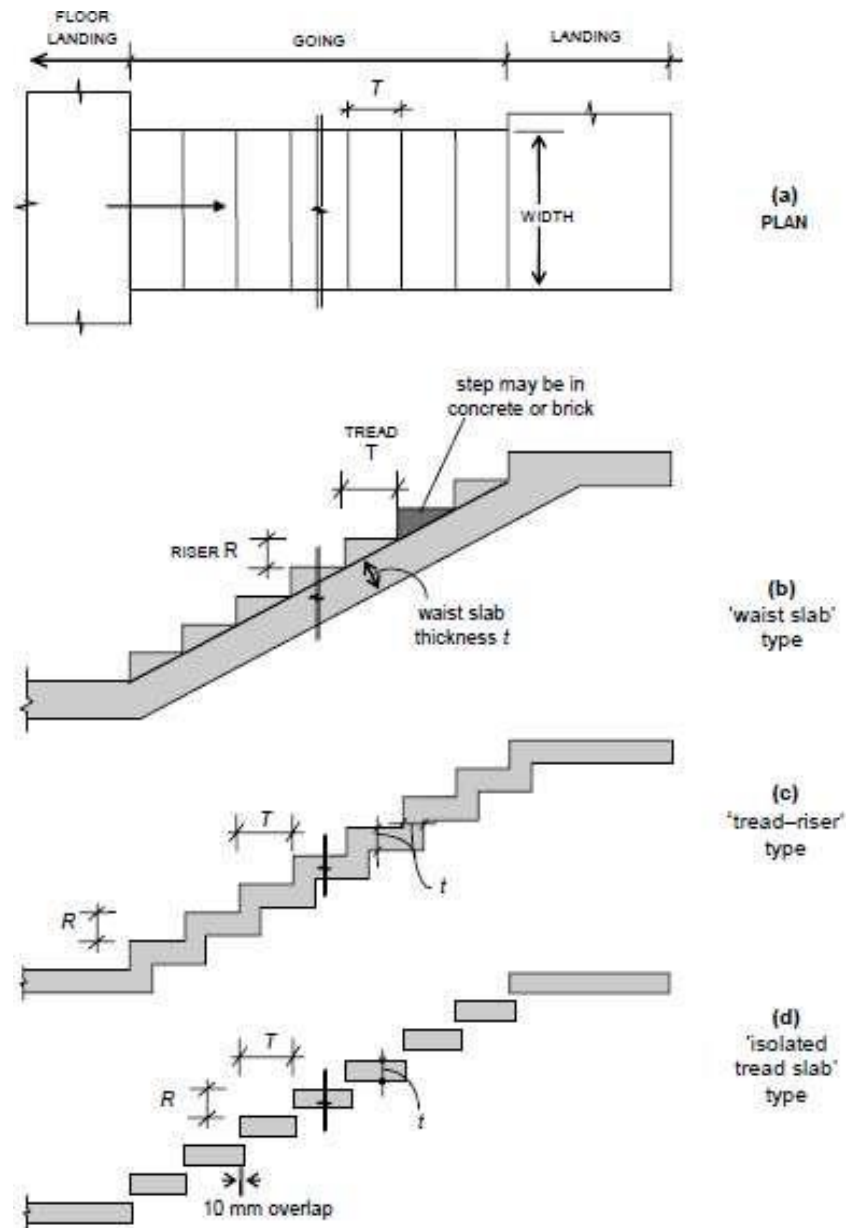

Figure 2.10 Typical flight in a staircase

## TYPES OF STAIRCASES

### Geometrical Configurations

A wide variety of staircases are met within practice. Some of the more common geometrical configurations are depicted in Fig. 2.11. These include:

- straight stairs (with or without intermediate landing) [Fig. 2.11(a)]
- quarter-turn stairs [Fig. 2.11(b)]
- dog-legged stairs [Fig. 2.11(c)]

- openwellstairs[Fig.2.11 (d)]
- spiralstairs[Fig.2.11(e)]
- helicoidalstairs[Fig.2.11(f)]

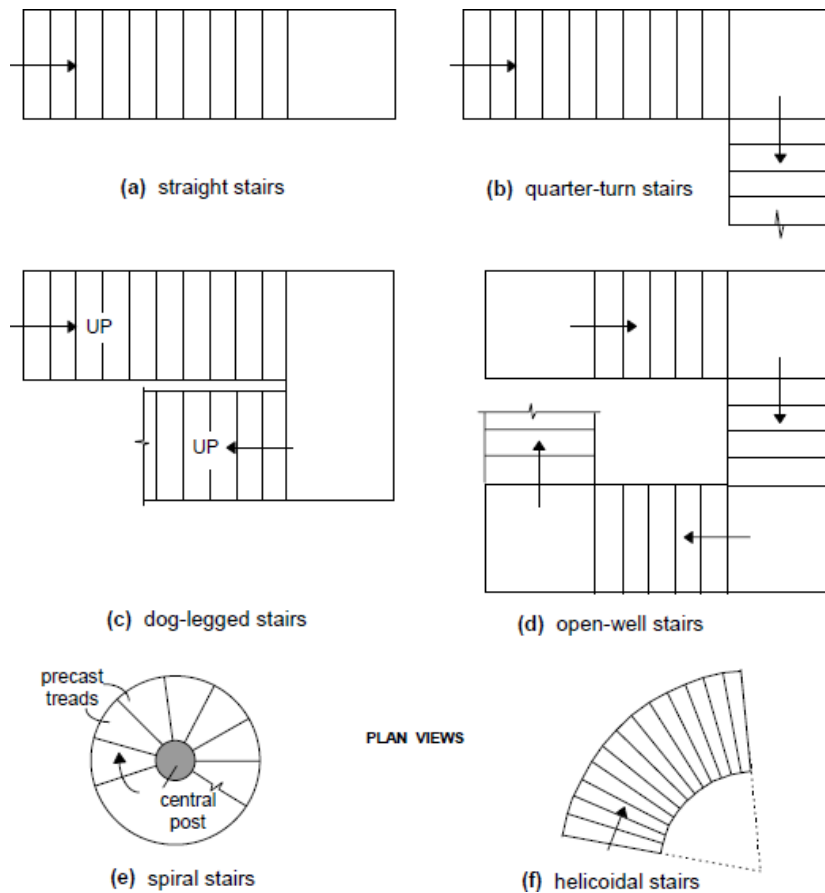

Fig.2.11 Common geometrical configurations of stairs

### Structural Classification

Structurally, staircases may be classified largely into two categories, depending on the predominant direction in which the slab component of the stair undergoes flexure:

1. Stair slab spanning transversely (stair widthwise);
2. Stair slab spanning longitudinally (along the incline).

### Stair Slab Spanning Transversely

The slab component of the stair (whether comprising an isolated tread slab, a tread-riser unit or a waist slab) is supported on its side(s) or cantilevers laterally from a central support. The slab supports gravity loads by bending essentially in a *transverse vertical plane*, with the span along the *width* of the stair.

In the case of the cantilevered slabs, it is economical to provide isolated treads (without risers). However, the tread-riser type of arrangement and the waist slab type are also sometimes employed in practice, as cantilevers. The spandrel beam is subjected to torsion (‘equilibrium torsion’), in addition to flexure and shear.

When the slab is supported at the two sides by means of ‘stringer beams’ or masonry walls, it may be designed as simply supported, but reinforcement at the top should be provided near the supports to resist the ‘negative’ moments that may arise on account of possible partial fixity.

### **Stair Slab Spanning Longitudinally**

In this case, the supports to the stair slab are provided parallel to the riser at two or more locations, causing the slab to bend longitudinally between the supports. It may be noted that longitudinal bending can occur in configurations other than the straight stair configuration, such as quarter-turn stairs, dog-legged stairs, open well stairs and helicoidal stairs.

The slab arrangement may either be the conventional ‘waist slab’ type or the ‘tread-riser’ type. The slab thickness depends on the ‘effective span’, which should be taken as the centre-to-centre distance between the beam/wall supports, according to the Code (Cl. 33.1a, c). In certain situations, beam or wall supports may not be available parallel to the riser at the landing. Instead, the flight is supported between the landings, which span transversely, parallel to the risers. In such cases, the Code (Cl. 33.1b) specifies that the effective span for the flight (spanning longitudinally) should be taken as *the going of the stairs plus at each end either half the width of the landing or one metre, whichever is smaller*.

### **Numerical Problem**

Design a (‘waist slab’ type) dog-legged staircase for an office building, given the following data:

- Height between floor = 3.2 m;
- Riser = 160 mm, tread = 270 mm;
- Width of flight = landing width = 1.25 m
- Live load =  $5.0 \text{ kN/m}^2$
- Finishes load =  $0.6 \text{ kN/m}^2$

Assume the stairs to be supported on 230 mm thick masonry walls at the outer edges of the landing, parallel to the risers [Fig. 12.13(a)]. Use M 20 concrete and Fe 415 steel. Assume mild exposure conditions.

## Solution

Given:  $R=160\text{mm}$ ,  $T=270\text{mm} \Rightarrow +RT22$

$= 314\text{mm}$  Effective span = c/c distance between supports =  $5.16\text{m}$  [Fig below].

- Assume a waist slab thickness  $\approx 120 = 5160/20 = 258 \rightarrow 260$  mm. Assuming  $20\text{mm}$  clear cover (*mild exposure*) and  $12\theta$  main bars, effective depth  $d=260-20-12/2= 234\text{mm}$ .  
The slab thickness in the landing regions may be taken as  $200\text{mm}$ , as the bending moments are relatively low here.

Loadson going [fig. below] on projected plan area:

(1) self-weight of waist slab @ $25 \times 0.26 \times 314/270$	$= 7.56\text{kN/m}^2$
(2) self-weight of steps @ $25 \times (0.5 \times 0.16)$	$= 2.00\text{kN/m}^2$
(3) finishes (given)	$= 0.60\text{kN/m}^2$
(4) live load (given)	$= 5.00\text{kN/m}^2$
Total	$= 15.16\text{kN/m}^2$

$\Rightarrow$  Factored load =  $15.16 \times 1.5 = 22.74\text{kN/m}^2$

### • Loadson landing

(1) self-weight of slab @ $25 \times 0.20$	$= 5.00\text{kN/m}^2$
(2) finishes	@ $0.6\text{kN/m}^2$
(3) live loads	@ $5.0\text{kN/m}^2$
Total	$= 10.60\text{kN/m}^2$

$\Rightarrow$  Factored load =  $10.60 \times 1.5 = 15.90\text{kN/m}^2$

### • Design Moment [Fig. below]

Reaction  $R = (15.90 \times 1.365) + (22.74 \times 2.43)/2 = 49.33\text{kN/m}$

Maximum moment at midspan:

$$M = (49.33 \times 2.58) - (15.90 \times 1.365) \times (2.58 - 1.365/2) - (22.74) \times (2.58 - 1.365)^2/2 = 69.30\text{kNm/m}$$

### • Main reinforcement

$$R = \frac{M_u}{bd^2} = 1.265 \text{ MPa}$$

Assuming  $f_{ck} = 20 \text{ MPa}$ ,  $f_y = 415 \text{ MPa}$ ,

$$\frac{P_t}{100} = \frac{A_{st}}{A_g} = 0.381 \times 10^{-2}$$

$$\Rightarrow (A_{st})_{req} = (0.381 \times 10^{-2}) \times 10^3 \times 234 = 892 \text{ mm}^2/\text{m}$$

Required spacing of 120 bars = 127 mm

Required spacing of 60 bars = 225 mm

**Provide 16@220 c/c**

• *Distributors*

$$(A_{st})_{req} = 0.0012bt = 312 \text{ mm}^2/\text{m}$$

spacing 100 bars = 251 mm

**Provide 10@250 c/c as distributors.**

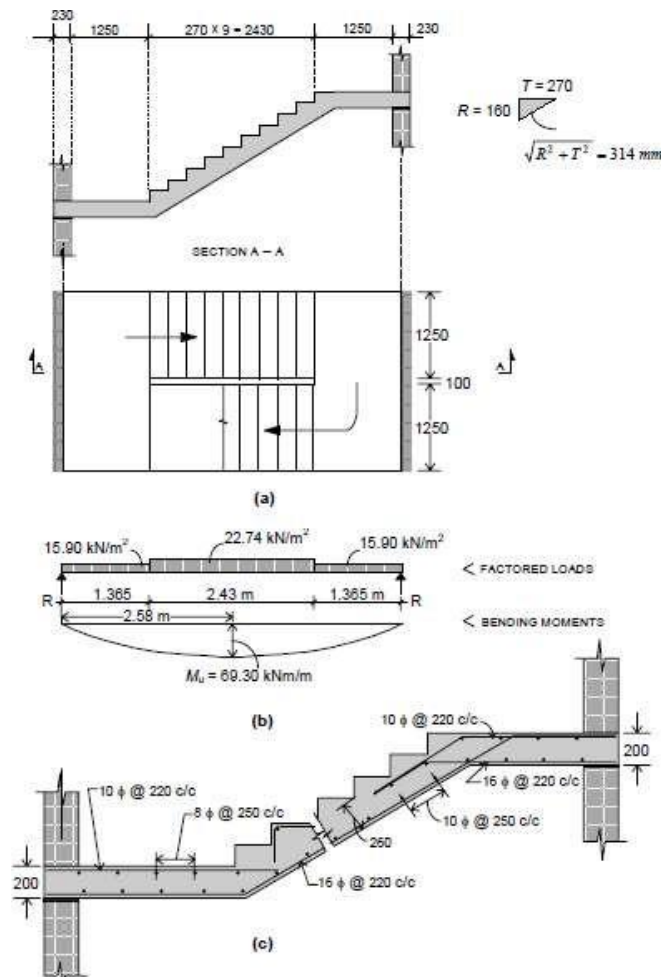

Figure for numerical problem

# MODULE-3

## Introduction

Compression members are structural elements primarily subjected to axial compressive forces and hence, their design is guided by considerations of strength and buckling. Examples of compression members are pedestal, column, wall and strut.

## Definitions

(a) Effective length: The vertical distance between the points of inflection of the compression member in the buckled configuration in a plane is termed as effective length  $l_e$  of that

compression member in that plane. The effective length is different from the unsupported length  $l$  of the member, though it depends on the unsupported length and the type of end restraints. The relation between the effective and unsupported lengths of any compression member is

$$l_e = k l \quad (1)$$

Where  $k$  is the ratio of effective to the unsupported lengths. Clause 25.2 of IS 456 stipulates the effective lengths of compression members (vide Annex E of IS 456). This parameter is needed in classifying and designing the compression members.

(b) Pedestal: Pedestal is a vertical compression member whose effective length  $l_e$  does not exceed three times of its least horizontal dimension  $b$  (cl. 26.5.3.1h, Note). The other horizontal dimension  $D$  shall not exceed four times of  $b$ .

(c) Column: Column is a vertical compression member whose unsupported length  $l$  shall not exceed sixty times of  $b$  (least lateral dimension), if restrained at the two ends. Further, its unsupported length of a cantilever column shall not exceed  $100b^2/D$ , where  $D$  is the larger lateral dimension which is also restricted up to four times of  $b$  (vide cl. 25.3 of IS 456).

(d) Wall: Wall is a vertical compression member whose effective height  $H_{we}$  to thickness  $t$  (least lateral dimension) shall not exceed 30 (cl. 32.2.3 of IS 456). The larger horizontal dimension i.e., the length of the wall  $L$  is more than  $4t$ .

## Classification of Columns Based on Types of Reinforcement

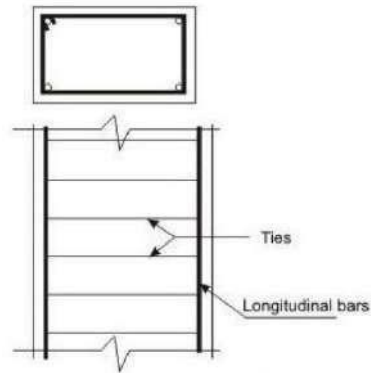

Figure 3.1(a) Tied Column

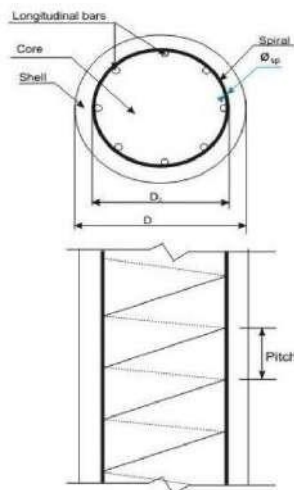

Figure 3.1(b) Column with helical reinforcement

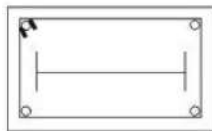

Figure 3.1(c) Composite column (steel section)

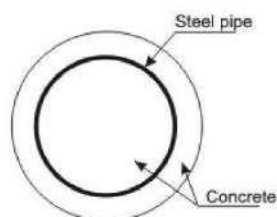

Figure 3.1(d) Composite column (steel pipe)

s

Based on the types of reinforcement, the reinforced concrete columns are classified into three groups:

(i) Tied columns: The main longitudinal reinforcement bars are enclosed within closely spaced lateral ties (Fig. 3.1a).

(ii) Columns with helical reinforcement: The main longitudinal reinforcement bars are enclosed within closely spaced and continuously wound spiral reinforcement. Circular and octagonal columns are mostly of this type (Fig. 3.1b).

(iii) Composite columns: The main longitudinal reinforcement of the composite columns consists of structural steel sections or pipes with or without longitudinal bars (Fig. 3.1c and d).

Out of the three types of columns, the tied columns are mostly common with different shapes of the cross-sections viz. square, rectangular etc. Helically bound columns are also used for circular or octagonal shapes of cross-sections.

### Classification of Columns Based on Loadings

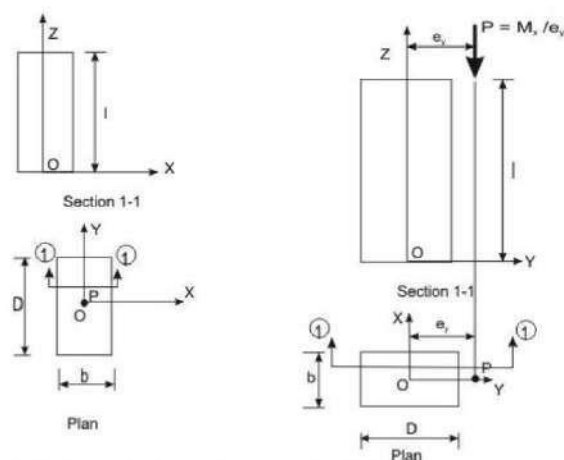

Figure 3.2(a) Axial loading (concentric) Figure 3.2(b) Axial loading with uniaxial bending

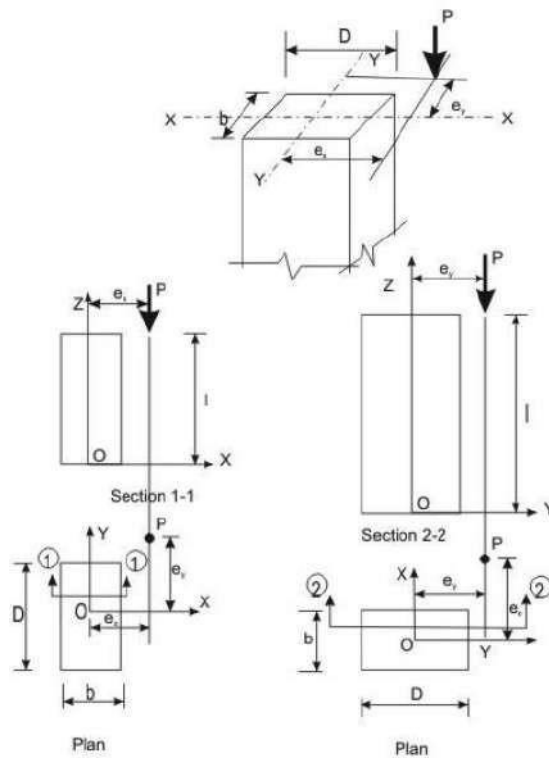

Figure 3.2(c) Axial loading with biaxial bending

Columns are classified into the three following types based on the loadings:

- (i) Columns subjected to axial load only (concentric), as shown in Fig. 3.2a.
- (ii) Columns subjected to combined axial load and uniaxial bending, as shown in Fig. 3.2b.
- (iii) Columns subjected to combined axial load and bi-axial bending, as shown in Fig. 3.2c.

### Classification of Columns Based on Slenderness Ratios

Columns are classified into the following two types based on the slenderness ratios:

- (i) Short columns
- (ii) Slender or long columns

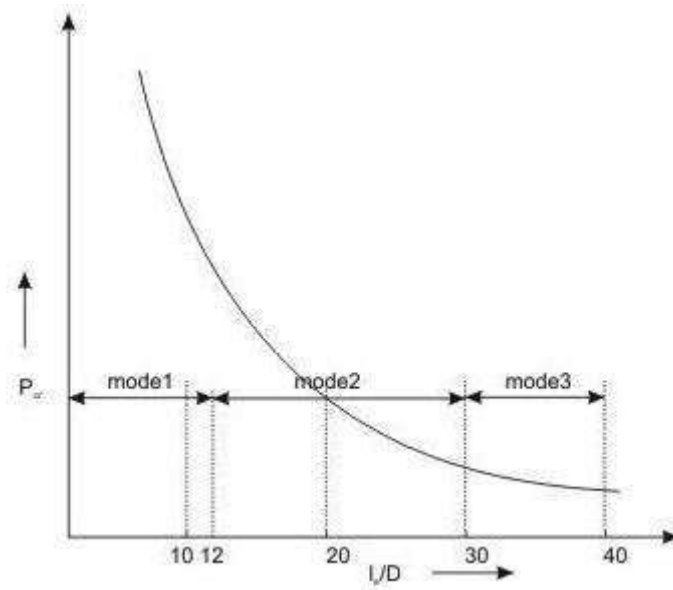

Figure 3.3 Modes of failure of columns

Figure 3.3 presents the three modes of failure of columns with different slenderness ratios when loaded axially. In the mode 1, column does not undergo any lateral deformation and collapses due to material failure. This is known as compression failure. Due to the combined effects of axial load and moment a short column may have material failure of mode 2. On the other hand, a slender column subjected to axial load only undergoes deflection due to beam-column effect and may have material failure under the combined action of direct load and bending moment. Such failure is called combined compression and bending failure of mode 2. Mode 3 failure is by elastic instability of very long column even under small load much before the material reaches the yield stresses. This type of failure is known as elastic buckling.

The slenderness ratio of steel column is the ratio of its effective length  $l_e$  to its least radius of gyration  $r$ . In case of reinforced concrete column, however, IS 456 stipulates the slenderness ratio as the ratio of its effective length  $l_e$  to its least lateral dimension. As mentioned earlier in sec. 3.1(a), the effective length  $l_e$  is different from the unsupported length, the rectangular reinforced concrete column of cross-sectional dimensions  $b$  and  $D$  shall have two effective lengths in the two directions of  $b$  and  $D$ . Accordingly, the column may have the possibility of buckling depending on the two values of slenderness ratios as given below:

Slenderness ratio about the major axis =  $l_{ex}/D$

Slenderness ratio about the minor axis =  $l_{ey}/b$

Based on the discussion above, cl. 25.1.2 of IS 456 stipulates the following:

A compression member may be considered as short when both the slenderness ratios  $l_e/D$

and  $l_e/b$  are less than 12 where  $l_e$  = effective length in respect of the major axis,  $D$  = depth in

respect of the major axis,  $l_e$  = effective length in respect of the minor axis, and  $b$  = width of

the member. It shall otherwise be considered as a slender compression member.

Further, it is essential to avoid the mode 3 type of failure of columns so that all columns should have material failure (modes 1 and 2) only. Accordingly, cl. 25.3.1 of

IS 456 stipulates the maximum unsupported length between two restraints of a column to be six times its least lateral dimension. For cantilever columns, when one end of the column is

unrestrained, the unsupported length is restricted to  $100b^2/D$  where  $b$  and  $D$  are as defined earlier.

### **Longitudinal Reinforcement**

The longitudinal reinforcing bars carry the compressive loads along with the concrete. Clause 26.5.3.1 stipulates the guidelines regarding the minimum and maximum amount, number of bars, minimum diameter of bars, spacing of bars etc. The following are the salient points:

- (a) The minimum amount of steel should be at least 0.8 per cent of the gross cross-sectional area of the column required if for any reason the provided area is more than the required area.
- (b) The maximum amount of steel should be 4 per cent of the gross cross-sectional area of the column so that it does not exceed 6 per cent when bars from column below have to be lapped with those in the column under consideration.
- (c) Four and six are the minimum number of longitudinal bars in rectangular and circular columns, respectively.
- (d) The diameter of the longitudinal bars should be at least 12 mm.
- (e) Columns having helical reinforcement shall have at least six longitudinal bars within and in contact with the helical reinforcement. The bars shall be placed equidistant around its inner circumference.
- (f) The bars shall be spaced not exceeding 300 mm along the periphery of the column.
- (g) The amount of reinforcement for pedestal shall be at least 0.15 per cent of the cross-sectional area provided.

## Transverse Reinforcement

Transverse reinforcing bars are provided in forms of circular rings, polygonal links (lateral ties) with internal angles not exceeding 135° or helical reinforcement. The transverse reinforcing bars are provided to ensure that every longitudinal bar nearest to the compression face has effective lateral support against buckling. Clause 26.5.3.2 stipulates the guidelines of the arrangement of transverse reinforcement. The salient points are:

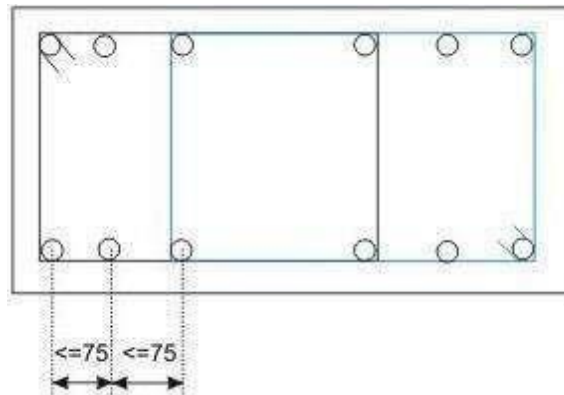

Figure 3.4 Lateral tie (Arrangement 1)

(a) Transverse reinforcement shall only go round corner and alternate bars if the longitudinal bars are not spaced more than 75 mm on either side (Fig. 3.4).

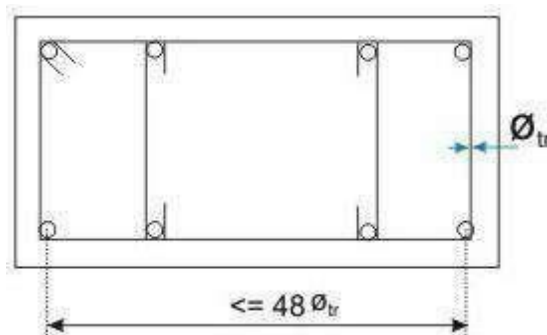

Figure 3.5 Lateral tie (Arrangement 2)

(b) Longitudinal bars spaced at a maximum distance of 48 times the diameter of the ties shall be tied by single tie and additional open ties for in between longitudinal bars (Fig. 3.5).

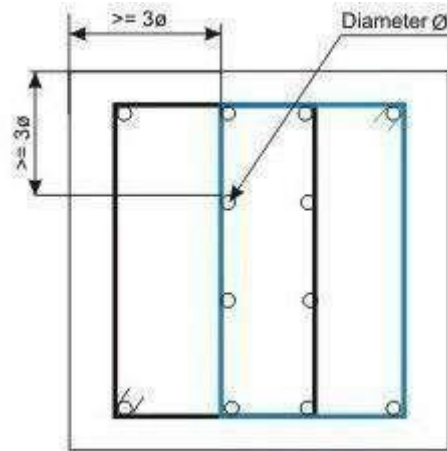

Figure 3.6 Lateral tie (Arrangement 3)

(c) For longitudinal bars placed in more than one row (Fig. 10.21.9): (i) transverse reinforcement is provided for the outer-most row in accordance with (a) above, and (ii) no bar of the inner row is closer to the nearest compression face than three times the diameter of the largest bar in the inner row.

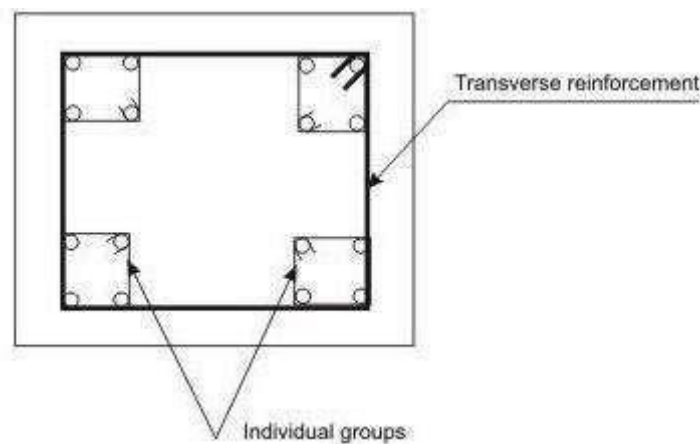

Figure 3.7 Lateral tie (Arrangement 4)

(d) For longitudinal bars arranged in a group such that they are not in contact and each group is adequately tied as per (a), (b) or (c) above, as appropriate, the transverse reinforcement for the compression member as a whole may be provided assuming that each group is a single longitudinal bar for determining the pitch and diameter of the transverse reinforcement.

The diameter of such transverse reinforcement should not, however, exceed 20 mm (Fig. 3.7).

### **Pitch and Diameter of Lateral Ties**

(a) Pitch: The maximum pitch of transverse reinforcement shall be the least of the following:

- (i) the least lateral dimension of the compression members;
- (ii) sixteen times the smallest diameter of the longitudinal reinforcement bar to be tied; and
- (iii) 300 mm.

(b) Diameter: The diameter of the polygonal links or lateral ties shall be not less than one-fourth of the diameter of the largest longitudinal bar, and in no case less than 6 mm.

### **Assumptions in the Design of Compression Members by Limit State of Collapse**

The following are the assumptions in addition to given in 38.1 (a) to (e) for flexure for the design of compression members (cl.39.1 of IS456).

- (i) The maximum compressive strain in concrete in axial compression is taken as 0.002.
- (ii) The maximum compressive strain at the highly compressed extreme fibre in concrete subjected to axial compression and bending and when there is no tension on the section shall be 0.0035 minus 0.75 times the strain at the least compressed extreme fibre.

### **Minimum Eccentricity**

In practical construction, columns are rarely truly concentric. Even a theoretical column loaded axially will have accidental eccentricity due to inaccuracy in construction or variation of materials etc. Accordingly, all axially loaded columns should be designed considering the minimum eccentricity as stipulated in cl.25.4 of IS456 and given below (Fig.3.2c)

$$e_{x \min} \geq \text{greater of } (l/500 + D/30) \text{ or } 20 \text{ mm}$$

$$e_{y \min} \geq \text{greater of } (l/500 + b/30) \text{ or } 20 \text{ mm}$$

where,  $l$ ,  $D$  and  $b$  are the unsupported length, larger lateral dimension and least lateral dimension, respectively.

### **Governing Equation for Short Axially Loaded Tied Columns**

Factored concentric load applied on short tied columns is resisted by concrete of area  $A_c$  and longitudinal steel of areas  $A_{sc}$  effectively held by lateral ties at intervals. Assuming the design strengths of concrete and steel are  $0.4f_{ck}$  and  $0.67f_y$ , respectively, we can write

$$P_u = 0.4f_{ck} A_c + 0.67f_y A_{sc} \quad (1)$$

Where  $P_u$  = factored axial load on the member,

$f_{ck}$  = characteristic compressive strength of the concrete,

$A_c$  = area of concrete,

$f_y$  = characteristic strength of the compression reinforcement, and

$A_{sc}$  = area of longitudinal reinforcement for columns.

The above equation, given in cl. 39.3 of IS 456, has two unknowns  $A_{sc}$  and  $A_g$  to be

determined from one equation. The equation is recast in terms of  $A_g$ , the gross area of

concrete and  $p$ , the percentage of compression reinforcement employing

$$A_{sc} = pA_g/100 \quad (2)$$

$$A_c = A_g(1 - p/100) \quad (3)$$

Accordingly, we can write

$$P_u/A_g = 0.4f_{ck} + (p/100)(0.67f_y - 0.4f_{ck}) \quad (4)$$

Equation 4 can be used for direct computation of  $A_g$  when  $P_u$ ,  $f_{ck}$  and  $f_y$  are known by assuming  $p$  ranging from 0.8 to 4 as the minimum and maximum percentages of longitudinal reinforcement. Equation 10.4 also can be employed to determine  $A_g$  and  $p$  in a similar manner by assuming  $p$ .

### Numerical Problem

Design the reinforcement in a column of size 400 mm x 600 mm subjected to an axial load of 2000 kN under service dead load and live load. The column has an unsupported length of 4.0m and effectively held in position and restrained against rotation in both ends. Use M 25 concrete and Fe 415 steel.

### Solution

#### Step 1: To check if the column is short or slender

Given  $l = 4000$  mm,  $b = 400$  mm and  $D = 600$  mm. Table 28 of IS 456 =  $l_{ex} = l_{ey} = 0.65(l)$

$l_{ex} = 2600$  mm. So, we have

$$l_{ex}/D = 2600/600 = 4.33 < 12$$

$$l_{ey}/b = 2600/400 = 6.5 < 12$$

Hence, it is a short column.

#### Step 2: Minimum eccentricity

$$e_{xmin} = \text{Greater of } (l_{ex}/500 + D/30) \text{ and } 20 \text{ mm} = 25.2 \text{ mm}$$

$$e_{ymin} = \text{Greater of } (l_{ey}/500 + b/30) \text{ and } 20 \text{ mm} = 20 \text{ mm}$$

$$0.05D = 0.05(600) = 30\text{mm} > 25.2\text{mm} (= e_{x\min})$$

$$0.05b = 0.05(400) = 20\text{mm} = 20\text{mm} (= e_{y\min})$$

Hence, the equation given in cl.39.3 of IS 456 (Eq.(1)) is applicable for the design here.

### Step 3: Area of steel

From Eq. 10.4, we have

$$P_u = 0.4f_{ck}A_{sc} + 0.67f_{ysc}A_{sc}$$

$$3000(10) = 0.4(25)\{(400)(600) - A_{sc}\} + 0.67(415)A_{sc}$$

which gives,

$$A_{sc} = 2238.39 \text{ mm}^2$$

Provide 6-20 mm diameter and 2-16 mm diameter rods giving  $2287 \text{ mm}^2 (> 2238.39 \text{ mm}^2)$  and  $p = 0.953$  per cent, which is more than minimum percentage of 0.8 and less than maximum percentage of 4.0. Hence, o.k.

### Step 4: Lateral ties

The diameter of transverse reinforcement (lateral ties) is determined from cl.26.5.3.2C-2 of IS 456 as not less than (i)  $\theta/4$  and (ii) 6mm. Here,  $\theta =$  largest bar diameter used as longitudinal reinforcement = 20 mm. So, the diameter of bars used as lateral ties = 6mm.

The pitch of lateral ties, as per cl.26.5.3.2C-1 of IS 456, should be not more than the least of

- (i) the least lateral dimension of the column = 400mm
- (ii) sixteen times the smallest diameter of longitudinal reinforcement bar to be tied =  $16(16) = 256\text{mm}$
- (iii) 300mm

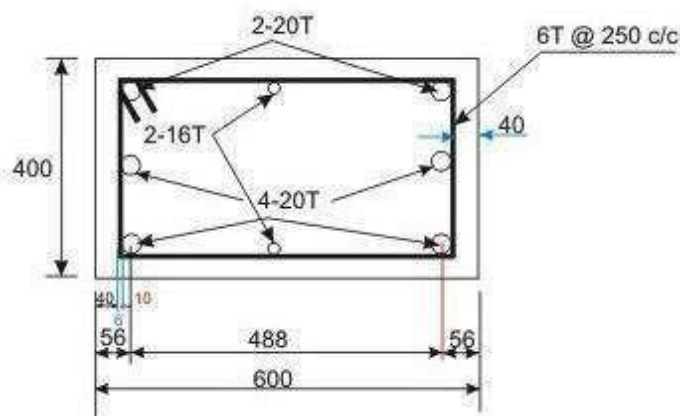

Reinforcement Detailing

Let us use  $p =$  pitch of lateral ties = 250mm.

## IS Code Method for Design of Columns under Axial Load and Biaxial Bending

IS 456 recommends the following simplified method, based on Bresler's formulation, for the design of biaxially loaded columns. The relationship between  $M_{ux}$  and  $M_{uy}$  for a particular value of  $P = P_u$ , expressed in non-dimensional form is:

$$\left(\frac{M_{ux}}{M_{ux1}}\right)^{\alpha^n} + \left(\frac{M_{uy}}{M_{uy1}}\right)^{\alpha^n} \leq 1 \quad (5)$$

where  $M_{ux}$  and  $M_{uy}$  = moments about x and y axes due to design loads, and

$\alpha^n$  is related to  $P/P_u$ ,

where

$$\begin{aligned} P &= 0.45f_{ck}A_g + 0.75f_y A_{sc} \\ &= 0.45A_g + (0.75f_y - 0.45f_{ck})A_{sc} \end{aligned} \quad (6)$$

where  $A_g$  = gross area of the section, and

$A_{sc}$  = total area of steel in the section

$M_{ux}$ ,  $M_{uy}$ ,  $M_{ux1}$  and  $M_{uy1}$  are explained earlier.

$\alpha^n = 1.0$ , when  $P/P_u \leq 0.2$

$\alpha^n = 0.67 + 1.67P/P_u$ , when  $0.2 < (P/P_u) < 0.8$  (7)

$\alpha^n = 2.0$ , when  $(P/P_u) \geq 0.8$

### Numerical Problem

Design the reinforcement to be provided in the short column is subjected to  $P_u = 2000$  kN,  $M_{ux} = 130$  kNm (about the major principal axis) and  $M_{uy} = 120$  kNm (about the minor principal axis). The unsupported length of the column is 3.2 m, width  $b = 400$  mm and depth  $D = 500$  mm. Use M25 and Fe415 for the design.

Solution

#### Step 1: Verification of the eccentricities

Given:  $l = 3200$  mm,  $b = 400$  mm and

$D = 500$  mm, The minimum eccentricities are:

$$e_{x_{min}} = \text{greater of } (3200/500 + 400/30) \text{ and } 20 \text{ mm} = 19.73 \text{ mm or } 20 \text{ mm} = 20 \text{ mm}$$

$$e_{y_{min}} = \text{greater of } (3200/500 + 500/30) \text{ and } 20 \text{ mm} = 23.07 \text{ mm or } 20 \text{ mm} = 23.07 \text{ mm}$$

Again from  $P_u = 2000 \text{ kN}$ ,  $M_{ux} = 130 \text{ kNm}$  and  $M_{uy} = 120 \text{ kNm}$ , we have  $e_x = M_{ux}/P_u = 130(10^3)/2000(10^3) = 65 \text{ mm}$  and  $e_y = M_{uy}/P_u = 120(10^3)/2000(10^3) = 60 \text{ mm}$ . Both  $e_x$  and  $e_y$  are greater than  $e_{x,min}$  and  $e_{y,min}$ , respectively.

### Step 2: Assuming a trial section including the reinforcement

We have  $b = 400 \text{ mm}$  and  $D = 500 \text{ mm}$ . For the reinforcement,  $M_u = 1.15(M_{ux}^2 + M_{uy}^2)$ , becomes  $203.456 \text{ kNm}$ . Accordingly,

$$P/f_b D = 2000(10^3)/(25)(400)(500) = 0.4$$

$$M/f_b D^2 = 203.456(10^6)/(25)(400)(500)(500) = 0.0814$$

Assuming  $d' = 60 \text{ mm}$ , we have  $d'/D = 0.12$ . From Charts 44 and 45, the value of  $p/f_{ck}$  is interpolated as  $0.06$ . Thus,  $p = 0.06(25) = 1.5$  percent, giving  $A_{sc} = 3000 \text{ mm}^2$ . Provide 12-20 mm diameter bars of area  $3769 \text{ mm}^2$ , actual  $p$  provided  $= 1.8845$  percent. So,  $p/f_{ck} = 0.07538$ .

### Step 3: Determination of $M_{ux1}$ and $M_{uy1}$

We have  $P/f_{ck} b D = 0.4$  and  $p/f_{ck} = 0.07538$  in step 2. Now, we get  $M_{ux1}/f_b D^2$  from chart 45, and get  $M_{ux1}/f_b D^2 = 0.09044$ . So,  $M_{ux1} = 0.09044(25)(400)(500)(500)(10^{-6}) = 226.1 \text{ kNm}$ .

For  $M_{uy1}$ ,  $d'/b = 58/400 = 0.145$ . In a similar manner, we get  $M_{uy1} = 0.0858(25)(400)(400)(500)(10^{-6}) = 171.6 \text{ kNm}$ .

As  $M_{ux1}$  and  $M_{uy1}$  are significantly greater than  $M_{ux}$  and  $M_{uy}$ , respectively, redesign of the section is not needed.

### Step 4: Determination of $P$ and $\alpha^n$

We have  $P = 0.45(25)(400)(500) + \{0.75(415) - 0.45(25)\}(3769) = 3380.7 \text{ kN}$ .

Now, the value of  $\alpha^n$  is obtained for  $P/P_u = 2000/3380.7 = 0.5916$ , i.e.,  $0.2 < P/P_u < 0.8$ , which gives,  $n\alpha = 0.67 + 1.67(P/P_u) = 1.658$ .

### Step 5: Checking the adequacy of the section

Using the values of  $M_{ux}$ ,  $M_{ux1}$ ,  $M_{uy}$ ,  $M_{uy1}$  and  $\alpha^n$  in Eq. (5), we have  $(130/226.1)^{1.658} + (120/171.6)^{1.658} = 0.9521 < 1.0$ . Hence, the design is safe.

### Step6:Designoftransverse reinforcement

As per cl.26.5.3.2c of IS 456, the diameter of lateral tie should be  $> (20/4)$  mm diameter. Provide 8 mm diameter bars following the arrangement shown in Fig.10.26.4. The spacing of lateral ties is the least of:

- (a) 400mm=least lateral dimension of column,
- (b) 320mm=sixteentimesthediameter oflongitudinalreinforcement(20mm),
- (c) 300mm

Accordingly, provide 8mm lateral tie alternately @ 250c/c (Fig.10.26.4).

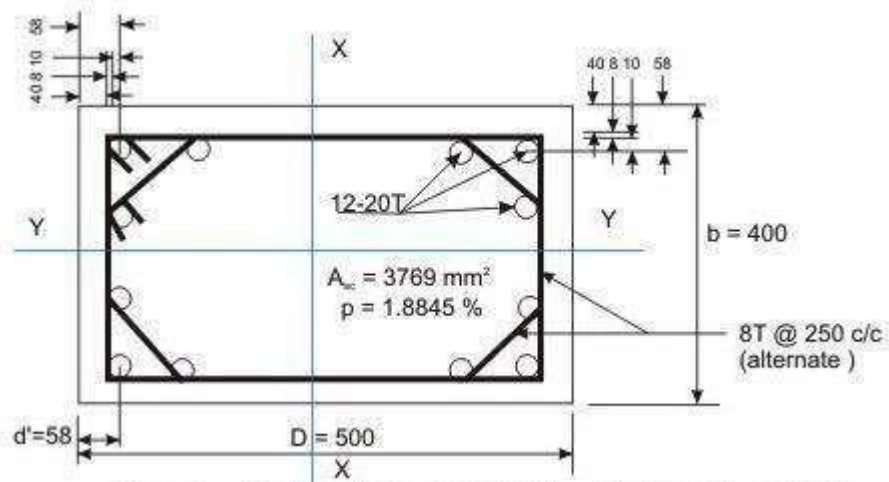

## **Design of isolated column footing.**

The superstructure is placed on the top of the foundation structure, designated as substructure as they are placed below the ground level. The elements of the superstructure transfer the loads and moments to its adjacent element below it and finally all loads and moments come to the foundation structure, which in turn, transfers them to the underlying soil or rock. Thus, the foundation structure effectively supports the superstructure. However, all types of soil get compressed significantly and cause the structure to settle. Accordingly, the major requirements of the design of foundation structures are the two as given below (see cl. 34.1 of IS 456):

1. Foundation structures should be able to sustain the applied loads, moments, forces and induced reactions without exceeding the safe bearing capacity of the soil.
2. The settlement of the structure should be as uniform as possible and it should be within the tolerable limits. It is well known from the structural analysis that differential settlement of supports causes additional moments in statically indeterminate structures. Therefore, avoiding the differential settlement is considered as more important than maintaining uniform overall settlement of the structure.

## **Types of Foundation Structures**

### **1. Shallow Foundation**

Shallow foundations are used when the soil has sufficient strength within a short depth below the ground level. They need sufficient plan area to transfer the heavy loads to the base soil. These heavy loads are sustained by the reinforced concrete columns or walls (either of bricks or reinforced concrete) of much less areas of cross-section due to high strength of bricks or reinforced concrete when compared to that of soil. The strength of the soil, expressed as the safe bearing capacity of the soil is normally supplied by the geotechnical experts to the structural engineer. Shallow foundations are also designated as footings. The different types of shallow foundations or footings are discussed below.

- (i) Plain concrete pedestal footings
- (ii) Isolated footings
- (iii) Combined footings
- (iv) Strap footings
- (v) Strip foundation or wall footings
- (vi) Raft or mat foundation

## **2. Deep foundations**

As mentioned earlier, the shallow foundations need more plan area due to the low strength of soil compared to that of masonry or reinforced concrete. However, shallow foundations are selected when the soil has moderately good strength, except the raft foundation which is good in poor condition of soil also. Raft foundations are under the category of shallow foundation as they have comparatively shallow depth than that of deep foundation. It is worth mentioning that the depth of raft foundation is much larger than those of other types of shallow foundations.

However, for poor condition of soil near to the surface, the bearing capacity is very less and foundation needed in such situation is the pile foundation. Piles are, in fact, small diameter columns which are driven or cast into the ground by suitable means. Precast piles are driven and cast-in-situ are cast. These piles support the structure by the skin friction between the pile surface and the surrounding soil and end bearing force, if such resistance is available to provide the bearing force. Accordingly, they are designated as frictional and end bearing piles. They are normally provided in a group with a pile cap at the top through which the loads of the superstructure are transferred to the piles.

Piles are very useful in marshy land where other types of foundation are impossible to construct. The length of the pile which is driven into the ground depends on the availability of hard soil/rock or the actual load test. Another advantage of the pile foundations is that they can resist uplift also in the same manner as they take the compression forces just by the skin friction in the opposite direction.

However, driving of pile is not an easy job and needs equipment and specially trained persons or agencies. Moreover, one has to select pile foundation in such a situation where the adjacent buildings are not likely to be damaged due to the driving of piles. The choice of driven or bored piles, in this regard, is critical.

Exhaustive designs of all types of foundations mentioned above are beyond the scope of this course. Accordingly, this module is restricted to the design of some of the shallow footings, frequently used for normal low rise buildings only.

## Isolated Footing

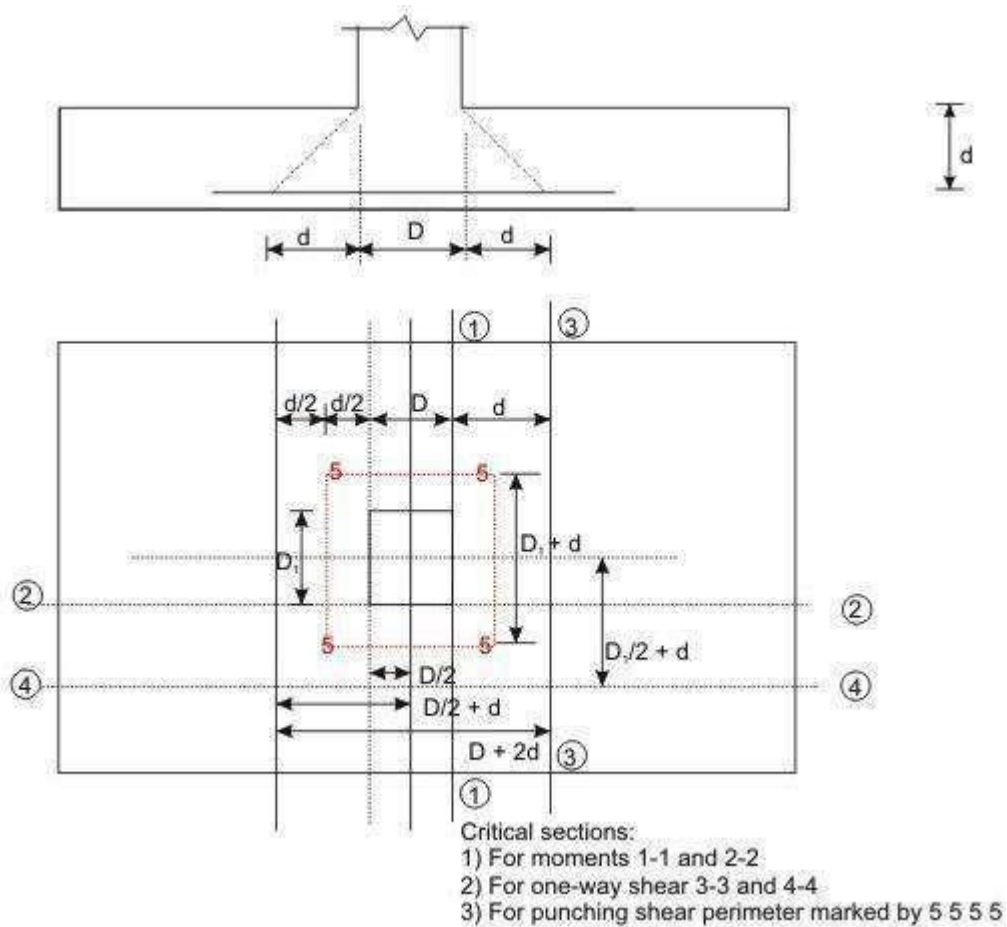

Figure 3.8: Uniform and rectangular footing

## Design Considerations

### (a) Minimum nominal cover (cl. 26.4.2.2 of IS 456)

The minimum nominal cover for the footings should be more than that of other structural elements of the superstructure as the footings are in direct contact with the soil. Clause 26.4.2.2 of IS 456 prescribes a minimum cover of 50 mm for footings. However, the actual cover may be even more depending on the presence of harmful chemicals or minerals, water table etc.

### (b) Thickness at the edge of footings (cls. 34.1.2 and 34.1.3 of IS 456)

The minimum thickness at the edge of reinforced and plain concrete footings shall be at least 150 mm for footings on soils and at least 300 mm above the top of piles for footings on piles, as per the stipulation in cl. 34.1.2 of IS 456.

For plain concrete pedestals, the angle  $\alpha$  (see Fig.11.28.1) between the plane passing through the bottom edge of the pedestal and the corresponding junction edge of the column with pedestal and the horizontal planes shall be determined from the following expression (cl.34.1.3 of IS 456)

$$\tan \alpha \leq 0.9 \{ (100 q_a / f_{ck}) + 1 \}^{0.5}$$

where  $q_a$  = calculated maximum bearing pressure at the base of pedestal in N/mm<sup>2</sup>, and

$f_{ck}$  = characteristic strength of concrete at 28 days in N/mm<sup>2</sup>.

**(c) Bending moments (cl.34.2 of IS 456)**

1. It may be necessary to compute the bending moment at several sections of the footing depending on the type of footing, nature of loads and the distribution of pressure at the base of the footing. However, bending moment at any section shall be determined taking all forces acting over the entire area on one side of the section of the footing, which is obtained by passing a vertical plane at that section extending across the footing (cl.34.2.3.1 of IS 456).

2. The critical section of maximum bending moment for the purpose of designing an isolated concrete footing which supports a column, pedestal or wall shall be:

- (i) at the face of the column, pedestal or wall for footing supporting a concrete column, pedestal or reinforced concrete wall, and
- (ii) halfway between the centre-line and the edge of the wall, for footing under masonry wall. This is stipulated in cl.34.2.3.2 of IS 456.

The maximum moment at the critical section shall be determined as mentioned in 1 above. For round or octagonal concrete column or pedestal, the face of the column or pedestal shall be taken as the side of a square inscribed within the perimeter of the round or octagonal column or pedestal (see cl.34.2.2 of IS 456 and Figs. 11.28.13a and b).

**(d) Shear force (cl.31.6 and 34.2.4 of IS 456)**

Footing slabs shall be checked in one-way or two-way shears depending on the nature of bending. If the slab bends primarily in one-way, the footing slab shall be checked in one-way vertical shear. On the other hand, when the bending is primarily two-way, the footing slab shall be checked in two-way shear or punching shear. The respective critical sections and design shear strengths are given below:

**1. One-way shear (cl.34.2.4 of IS 456)**

One-way shear has to be checked across the full width of the base slab on a vertical section located from the face of the column, pedestal or wall at a distance equal to

- (i) effective depth of the footing slab in case of footing slab on soil, and
- (ii) half the effective depth of the footing slab if the footing slab is on piles.

The design shear strength of concrete without shear reinforcement is given in Table 19 of cl. 40.2 of IS 456.

## **2. Two-way or punching shear (cls. 31.6 and 34.2.4)**

Two-way or punching shear shall be checked around the column on a perimeter half the effective depth of the footing slab away from the face of the column or pedestal.

The permissible shear stress, when shear reinforcement is not provided, shall not exceed  $k_s \tau_c$ , where  $k = (0.5 + c\beta)$ , but not greater than one,  $c\beta$  being the ratio of short side to long side of

the column, and  $\tau_c = 0.25 (f_{ck})^{1/2}$  in limit state method of design, as stipulated in cl. 31.6.3 of IS 456.

Normally, the thickness of the base slab is governed by shear. Hence, the necessary thickness of the slab has to be provided to avoid shear reinforcement.

### **(e) Bond (cl. 34.2.4.3 of IS 456)**

The critical section for checking the development length in a footing slab shall be the same planes as those of bending moments in part (c) of this section. Moreover, development length shall be checked at all other sections where they change abruptly. The critical sections for checking the development length are given in cl. 34.2.4.3 of IS 456, which further recommends to check the anchorage requirements if the reinforcement is curtailed, which shall be done in accordance with cl. 26.2.3 of IS 456.

### **(f) Tensile reinforcement (cl. 34.3 of IS 456)**

The distribution of the total tensile reinforcement, calculated in accordance with the moment at critical sections, as specified in part (c) of this section, shall be done as given below for one-way and two-way footing slabs separately.

(i) In one-way reinforced footing slabs like wall footings, the reinforcement shall be distributed uniformly across the full width of the footing i.e., perpendicular to the direction of wall. Nominal distribution reinforcement shall be provided as per cl. 34.5 of IS 456 along the length of the wall to take care of these secondary moment, differential settlement, shrinkage and temperature effects.

(i) In two-way reinforced square footing slabs, the reinforcement extending in each direction shall be distributed uniformly across the full width/length of the footing.

(i) In two-way reinforced rectangular footing slabs, the reinforcement in the long direction shall be distributed uniformly across the full width of the footing slab. In the short direction, a central band equal to the width of the footing shall be marked along the length of the footing, where the portion of the reinforcement shall be determined as given in the equation below. This portion of the reinforcement shall be distributed across the central band:

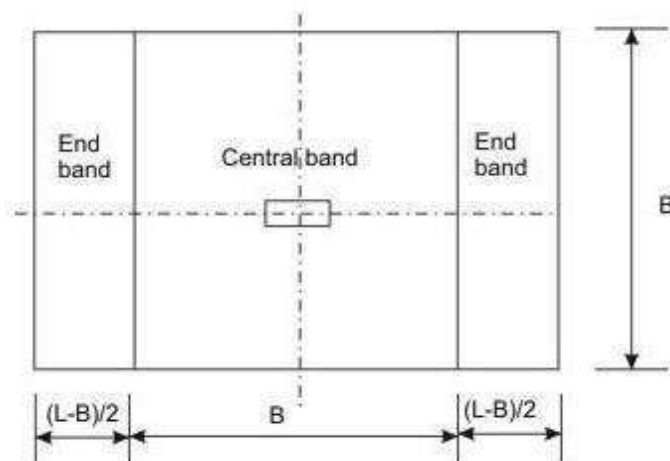

Figure 3.10

Bands for reinforcement in rectangular footing  
 Reinforcement in the central band =  $\frac{2}{(\beta+1)}$  (Total reinforcement in the short direction)

Where  $\beta$  is the ratio of longer dimension to shorter dimension of the footing slab (Fig. 3.10).

Each of the two end bands shall be provided with half of the remaining reinforcement, distributed uniformly across the respective end band.

**(g) Transfer of load at the base of column (cl. 34.4 of IS 456)**

All forces and moments acting at the base of the column must be transferred to the pedestal, if any, and then from the base of the pedestal to the footing, (or directly from the base of the column to the footing if there is no pedestal) by compression in concrete and steel and tension in steel. Compression forces are transferred through direct bearing while tension forces are transferred through developed reinforcement. The permissible bearing stresses on full area of concrete shall be taken as given below from cl. 34.4 of IS 456:

$$\sigma_{br} = 0.25f_{ck}, \text{ in working stress method, and}$$

$$\sigma_{br} = 0.45f_{ck}, \text{ in limit state method}$$

The stress of concrete is taken as  $0.45f_{ck}$  while designing the column. Since the area of footing is much larger, this bearing stress of concrete in column may be increased

considering the dispersion of the concentrated load of column to footing. Accordingly, the permissible bearing stress of concrete in footing is given by (cl.34.4 of IS 456):

$$\sigma_{br} = 0.45 f_{ck} \left( \frac{A_1}{A_2} \right)^{1/2}$$

with a condition that

$$\left( \frac{A_1}{A_2} \right)^{1/2} \leq 2.0 \text{ (11.8)}$$

where  $A_1$  = maximum supporting area of footing for bearing which is geometrically similar to and concentric with the loaded area  $A_2$ .

$A_2$  = loaded area at the base of the column.

The above clause further stipulates that in sloped or stepped footings,  $A_1$  may be taken as the

area of the lower base of the largest frustum of a pyramid or cone contained wholly within the footing and having for its upper base, the area actually loaded and having side slope of one vertical to two horizontal.

If the permissible bearing stress on concrete in column or in footing is exceeded, reinforcement shall be provided for developing the excess force (cl.34.4.1 of IS 456), either by extending the longitudinal bars of columns into the footing (cl.34.4.2 of IS 456) or by providing dowels as stipulated in cl.34.4.3 of IS 456 and given below:

- (i) Sufficient development length of reinforcement shall be provided to transfer the compression or tension to the supporting member in accordance with cl.26.2 of IS 456, when transfer of force is accomplished by reinforcement of column (cl.34.4.2 of IS 456).
- (ii) Minimum area of extended longitudinal bars or dowels shall be 0.5 per cent of the cross-sectional area of the supported column or pedestal (cl.34.4.3 of IS 456).
- (iii) A minimum of four bars shall be provided (cl.34.4.3 of IS 456).
- (iv) The diameter of dowels shall not exceed the diameter of column bars by more than 3mm.
- (v) Column bars of diameter larger than 36 mm, in compression only can be doweled at the footings with bars of smaller size of the necessary area. The dowel shall extend into the column, a distance equal to the development length of the column bar and into the footing, a distance equal to the development length of the dowel, as stipulated in cl.34.4.4 of IS 456.

**(h) Nominal reinforcement (cl.34.5 of IS 456)**

Clause 34.5.1 of IS 456 stipulates the minimum reinforcement and spacing of the bars in footing slabs as per the requirements of solid slab (cls.26.5.2.1 and 26.3.3b(2) of IS 456, respectively).

### **Numerical Problem**

Design an isolated footing of uniform thickness of a RC column bearing a vertical load of 600 KN and having a base of size 500x500mm. the safe bearing capacity of soil may be taken as 120KN/m<sup>2</sup>. Use M20 concrete and Fe 415 steel.

### **Solution**

#### Size of footing

W=600KN;

Self weight of footing @ 10% =60

KN Total load=660KN

Size of footing=660/120 =5.5m<sup>2</sup>

Since square footing, B=  $\sqrt{5.5} = 2.345$

m<sup>2</sup> Provide a square footing=2.4mx2.4m

Net upward pressure,  $p_0=600/(2.4 \times 2.4)=104.17 \text{KN/m}^2$  Design

#### Design of section

The maximum BM acts at the face of column M=

$$p_0 \frac{B}{8} (B-b) = 112.8 \text{KN-m}$$

Mu=1.5M=169.2KN-m

Therefore

=160mm; D=160+60=220mm Depth on the basis

#### Design of one-way shear

For one-way shear, critical section is located at a distance d from the face of the column where shear force V is given by

$$V = p_o B \{0.5(B-b) - d\} = 104.17 \times 2.4 \{0.5 \times (2.4 - 0.5) - 0.001d\}$$

$$V_u = 1.5V$$

$$\tau_c = \frac{V_u}{bd} = \frac{375012(0.95 - 0.001d)}{400d}$$

From table B.5.2.1.1 of IS 456:2000  $k = 1.16$  for  $D = 220$  mm.

Also for under-reinforced section with  $p_t = 0.3\%$  for M20 concrete,  $\tau_c = 0.384$

$N/mm^2$ . Hence design shear stress  $= k\tau_c = 0.445 N/mm^2$

From which we get  $d = 246.7 \approx 250$

mm Depth for two ways shear

Take greater one of the two i.e. 250 mm. For two-way shear, the section lies at  $d/2$  from the column face all round. The width of the section  $= b + d = 750$  mm

Shear force around the section

$$F = p_o [B^2 - b_o^2] = 541.42 \text{ KN}$$

$$F_u = 1.5F$$

$$\tau_v = \frac{F_u}{4b_o d} = \frac{812.13 \times 10^6}{4 \times 750 \times 250} = 1.083 N/mm^2$$

Permissible shear stress  $= k_s \tau_c$

Where  $k_s = (0.5 + \beta_c) = (0.5 + 1)$  with a maximum value 1.  $k_s = 1$

$$\tau_c = 0.25 \sqrt{f_{ck}}$$

$$= 1.118 N/mm^2 \text{ Permissible}$$

leshear stress  $= 1.118 N/mm^2$  Hence safe.

Hence  $d = 250$  mm, using 60 mm effective cover and keeping  $D = 330$  mm, effective depth  $= 330 - 60 = 270$  mm in one direction and other direction  $d = 270 - 12 = 258$  mm.

Calculation of reinforcement

$$A_{st} = 1944 \text{ mm}^2$$

Using 12 mm bars, spacing required  $= 138.27$  mm

So provide 12mm @ 125c/c in each direction. Deve

lopment length

$$L_d = 564 \text{ mm}$$

Provide 60 mm side cover, length of bars available =  $0.5[B-b]-60=890 \text{ mm}$

>  $L_d$  So safe.

Transfer of load at

column base  $A_2 = 500 \times 500$

$$= 250000 \text{ mm}^2 \quad A_1 = [500 + 2(2 \times 330)] =$$

$$3312400 \text{ mm}^2$$

$$\sqrt{\frac{A_1}{A_2}}$$

$$= 3.64$$

$$\text{Taking } \sqrt{\frac{A_1}{A_2}} = 2$$

Hence permissible

bearing stress =  $18 \text{ KN/m}^2$  Actual bearing stress =

$$3.6 \text{ N/mm}^2$$

Hence safe.

